

[MS-WSSTS]: Windows SharePoint Services

Intellectual Property Rights Notice for Open Specifications Documentation

- **Technical Documentation.** Microsoft publishes Open Specifications documentation for protocols, file formats, languages, standards as well as overviews of the interaction among each of these technologies.
- **Copyrights.** This documentation is covered by Microsoft copyrights. Regardless of any other terms that are contained in the terms of use for the Microsoft website that hosts this documentation, you may make copies of it in order to develop implementations of the technologies described in the Open Specifications and may distribute portions of it in your implementations using these technologies or your documentation as necessary to properly document the implementation. You may also distribute in your implementation, with or without modification, any schema, IDL's, or code samples that are included in the documentation. This permission also applies to any documents that are referenced in the Open Specifications.
- **No Trade Secrets.** Microsoft does not claim any trade secret rights in this documentation.
- **Patents.** Microsoft has patents that may cover your implementations of the technologies described in the Open Specifications. Neither this notice nor Microsoft's delivery of the documentation grants any licenses under those or any other Microsoft patents. However, a given Open Specification may be covered by Microsoft [Open Specification Promise](#) or the [Community Promise](#). If you would prefer a written license, or if the technologies described in the Open Specifications are not covered by the Open Specifications Promise or Community Promise, as applicable, patent licenses are available by contacting iplg@microsoft.com.
- **Trademarks.** The names of companies and products contained in this documentation may be covered by trademarks or similar intellectual property rights. This notice does not grant any licenses under those rights. For a list of Microsoft trademarks, visit www.microsoft.com/trademarks.
- **Fictitious Names.** The example companies, organizations, products, domain names, email addresses, logos, people, places, and events depicted in this documentation are fictitious. No association with any real company, organization, product, domain name, email address, logo, person, place, or event is intended or should be inferred.

Reservation of Rights. All other rights are reserved, and this notice does not grant any rights other than specifically described above, whether by implication, estoppel, or otherwise.

Tools. The Open Specifications do not require the use of Microsoft programming tools or programming environments in order for you to develop an implementation. If you have access to Microsoft programming tools and environments you are free to take advantage of them. Certain Open Specifications are intended for use in conjunction with publicly available standard specifications and network programming art, and assumes that the reader either is familiar with the aforementioned material or has immediate access to it.

Revision Summary

Date	Revision History	Revision Class	Comments
04/04/2008	0.1		Initial Availability
06/27/2008	1.0	Major	Revised and edited the technical content
12/12/2008	1.01	Editorial	Revised and edited the technical content
07/13/2009	1.02	Major	Revised and edited the technical content
08/28/2009	1.03	Editorial	Revised and edited the technical content
11/06/2009	1.04	Editorial	Revised and edited the technical content
02/19/2010	2.0	Major	Updated and revised the technical content
03/31/2010	2.01	Editorial	Revised and edited the technical content
04/30/2010	2.02	Editorial	Revised and edited the technical content
06/07/2010	2.03	Editorial	Revised and edited the technical content
06/29/2010	2.04	Minor	Clarified the meaning of the technical content.
07/23/2010	2.05	Editorial	Changed language and formatting in the technical content.
09/27/2010	2.05	No change	No changes to the meaning, language, or formatting of the technical content.
11/15/2010	2.05	No change	No changes to the meaning, language, or formatting of the technical content.
12/17/2010	2.05	No change	No changes to the meaning, language, or formatting of the technical content.
03/18/2011	2.5.1	Editorial	Changed language and formatting in the technical content.
06/10/2011	2.5.1	No change	No changes to the meaning, language, or formatting of the technical content.
01/20/2012	3.0	Major	Significantly changed the technical content.
04/11/2012	3.0	No change	No changes to the meaning, language, or formatting of the technical content.
07/16/2012	3.0	No change	No changes to the meaning, language, or formatting of the technical content.
09/12/2012	3.0	No change	No changes to the meaning, language, or formatting of the technical content.
10/08/2012	3.1	Minor	Clarified the meaning of the technical content.

Date	Revision History	Revision Class	Comments
02/11/2013	3.1	No change	No changes to the meaning, language, or formatting of the technical content.
07/30/2013	3.2	Minor	Clarified the meaning of the technical content.
11/18/2013	3.2	No change	No changes to the meaning, language, or formatting of the technical content.
02/10/2014	3.2	No change	No changes to the meaning, language, or formatting of the technical content.

Table of Contents

1 Introduction	7
1.1 Glossary	7
1.2 References	8
1.2.1 Normative References	8
1.2.2 Informative References	9
1.3 Overview	9
1.4 Relationship to Protocols and Other Structures	9
1.5 Applicability Statement	9
1.6 Versioning and Localization	9
1.7 Vendor-Extensible Fields	10
2 Structures	11
2.1 Abstract Data Structures	11
2.1.1 Administration and Configuration	11
2.1.1.1 Farm	11
2.1.1.2 Administration Object	12
2.1.1.3 Service	12
2.1.1.3.1 Content Web Service Object	12
2.1.1.3.2 Administration Web Service Object	12
2.1.1.4 Web Application	12
2.1.2 Content	13
2.1.2.1 Namespace	13
2.1.2.2 Managed Path	14
2.1.2.3 Folder	14
2.1.2.4 File	14
2.1.2.5 Site Collection	15
2.1.2.6 Site	15
2.1.2.7 List	15
2.1.2.7.1 Document Library	16
2.1.2.7.2 UserInfo List	16
2.1.2.8 Content Type	16
2.1.2.8.1 Content Type Id	17
2.1.2.9 Field	17
2.1.2.9.1 Field Type and Field Internal Type	17
2.1.2.10 List Item	17
2.1.2.11 Document	18
2.1.2.11.1 Document Processes	18
2.1.2.11.1.1 Publishing Level	18
2.1.2.11.1.2 Versioning	18
2.1.2.11.1.3 Checking In and Out	19
2.1.2.11.1.4 Conversion	19
2.1.2.12 Generic List Items	19
2.1.2.13 Metadict	20
2.1.2.14 Workflow	20
2.1.2.14.1 Workflow Template	20
2.1.2.14.2 Workflow Associations	20
2.1.2.15 HTML User Interface Infrastructure	20
2.1.2.15.1 Page	20
2.1.2.15.2 Web Part	21
2.1.2.15.3 View	21

2.1.2.15.4	Form.....	21
2.1.2.16	Navigation Structure	21
2.1.2.16.1	Navigation Nodes	21
2.1.2.16.2	Navigation Node Identifiers.....	22
2.1.3	Provisioning Data Structures.....	22
2.1.3.1	Site Definition	22
2.1.3.2	List Definition.....	22
2.1.3.3	Feature	23
2.1.4	Authentication and Security.....	23
2.1.4.1	Authentication System	23
2.1.4.1.1	Authentication System User.....	23
2.1.4.1.2	Authentication System Group	24
2.1.4.2	Principal	24
2.1.4.3	Group	24
2.1.4.4	Securable Object	24
2.1.4.5	Scope.....	24
2.1.4.6	Permission.....	24
2.1.4.7	Read My Own, Write My Own	25
2.1.4.8	Role Definition.....	25
2.2	Object-Level Constraints and Requirements	25
2.2.1	File System Object Constraints.....	25
2.2.2	Site Constraints	26
2.3	Field Types	26
2.3.1	Base Field Types	26
2.3.2	Extended Field Types	28
2.4	Common Fields.....	28
2.4.1	Document Lookup	28
2.4.2	Base Data Fields	28
2.4.3	Base Rendering Fields.....	32
2.4.4	XML Document Data Fields	33
2.4.5	XML Document Rendering Fields.....	33
2.4.6	Survey Data Fields	34
2.5	List Base Types	34
2.5.1	Common List Item Fields.....	34
2.5.1.1	Data Fields	34
2.5.1.2	HTML Rendering Fields	35
2.5.2	Generic List	36
2.5.2.1	Data Fields	36
2.5.2.2	HTML Rendering Fields	36
2.5.3	Document	37
2.5.3.1	Data Fields	37
2.5.3.2	HTML Rendering Fields	38
2.5.4	Discussion Board.....	38
2.5.4.1	Data Fields	38
2.5.4.2	HTML Rendering Fields	39
2.5.5	Survey.....	39
2.5.5.1	Data Fields	40
2.5.5.2	HTML Rendering Fields	40
2.5.6	Issue	40
2.5.6.1	Data Fields	40
2.5.6.2	HTML Rendering Fields	41
2.6	Content Types.....	41
2.6.1	Base Content Types.....	41

2.6.1.1	System	41
2.6.1.2	Item	42
2.6.1.3	Document.....	42
2.6.1.4	Folder	42
2.7	List Template Types	43
2.8	Common Data Structures and Enumerations	44
2.8.1	WorkflowEventType Enumeration	44
2.8.2	WorkflowStatus.....	44
2.9	Expressions.....	45
2.9.1	Syntax	45
2.9.2	Function Names	46
3	Structure Examples	53
4	Security.....	55
4.1	Security Considerations for Implementers.....	55
4.2	Index of Security Fields	55
5	Appendix A: Product Behavior	56
6	Change Tracking.....	58
7	Index	59

1 Introduction

The Windows SharePoint Services contain common definitions and data structures that are used in various protocols in the set of protocols. This document also specifies high-level SharePoint concepts necessary for understanding those protocols. The documentation for individual protocols contains references to this document, as needed.

Sections 1.7 and 2 of this specification are normative and can contain the terms MAY, SHOULD, MUST, MUST NOT, and SHOULD NOT as defined in RFC 2119. All other sections and examples in this specification are informative.

1.1 Glossary

The following terms are defined in [\[MS-GLOS\]](#):

access control list (ACL)
Augmented Backus-Naur Form (ABNF)
GUID
principal

The following terms are defined in [\[MS-OFCGLOS\]](#):

absolute URL
base field type
base type
base URL
computed field
content database
content type
content type identifier
content type schema
current version
directory name
document library
Document Workspace site
farm
field
field internal name
field type
file
folder
front-end web server
group
item identifier
list
list identifier
list item
lookup field
major version
Meeting Workspace site
metadict
minor version
navigation node
navigation node element identifier
ProgID

publishing level
role definition
securable object
security scope
server-relative URL
site
site collection
site definition
site identifier
site template
store-relative URL
SystemID
uncustomized
Uniform Resource Locator (URL)
user interface (UI) version
web application
Web Part
Web Part zone
XML document
XML Path Language (XPath)

The following terms are specific to this document:

alternate access mapping: A mapping of URLs to web applications. Incoming alternate access mappings are used to provide multiple URL entry points for the same set of content. Outgoing alternate access mappings are used to ensure that content is rendered in the correct URL context.

MAY, SHOULD, MUST, SHOULD NOT, MUST NOT: These terms (in all caps) are used as described in [\[RFC2119\]](#). All statements of optional behavior use either MAY, SHOULD, or SHOULD NOT.

1.2 References

References to Microsoft Open Specifications documentation do not include a publishing year because links are to the latest version of the documents, which are updated frequently. References to other documents include a publishing year when one is available.

1.2.1 Normative References

We conduct frequent surveys of the normative references to assure their continued availability. If you have any issue with finding a normative reference, please contact dochelp@microsoft.com. We will assist you in finding the relevant information.

[ISO/IEC29500-1:2011] ISO/IEC, "Information Technology -- Document description and processing languages -- Office Open XML File Formats -- Part 1: Fundamentals and Markup Language Reference", ISO/IEC 29500-1:2011, 2011,
http://www.iso.org/iso/iso_catalogue/catalogue_tc/catalogue_detail.htm?csnumber=59575

[MS-FPSE] Microsoft Corporation, "[FrontPage Server Extensions Remote Protocol](#)".

[MS-WSSCAML] Microsoft Corporation, "[Collaborative Application Markup Language \(CAML\) Structure](#)".

[MS-WSSFO3] Microsoft Corporation, "[Windows SharePoint Services \(WSS\): File Operations Database Communications Version 3 Protocol](#)".

[RFC2119] Bradner, S., "Key words for use in RFCs to Indicate Requirement Levels", BCP 14, RFC 2119, March 1997, <http://www.rfc-editor.org/rfc/rfc2119.txt>

[RFC2396] Berners-Lee, T., Fielding, R., and Masinter, L., "Uniform Resource Identifiers (URI): Generic Syntax", RFC 2396, August 1998, <http://www.ietf.org/rfc/rfc2396.txt>

[RFC3986] Berners-Lee, T., Fielding, R., and Masinter, L., "Uniform Resource Identifier (URI): Generic Syntax", STD 66, RFC 3986, January 2005, <http://www.ietf.org/rfc/rfc3986.txt>

[RFC5234] Crocker, D., Ed., and Overell, P., "Augmented BNF for Syntax Specifications: ABNF", STD 68, RFC 5234, January 2008, <http://www.rfc-editor.org/rfc/rfc5234.txt>

[W3C-XML] Bray, T., Paoli, J., Sperberg-McQueen, C.M., Maler, E., Yergeau, F., Eds., "Extensible Markup Language (XML) 1.1 (Second Edition)", W3C Recommendation, August 2006, <http://www.w3.org/TR/2006/REC-xml11-20060816/>

1.2.2 Informative References

[MSDN-SharePointSDK] Microsoft Corporation, "SharePoint Products and Technologies SDK: 2010 API Reference (Technical Preview)", July 2009, [http://msdn.microsoft.com/en-us/library/ee557253\(office.14\).aspx](http://msdn.microsoft.com/en-us/library/ee557253(office.14).aspx)

[MS-GLOS] Microsoft Corporation, "[Windows Protocols Master Glossary](#)".

[MS-OFCGLOS] Microsoft Corporation, "[Microsoft Office Master Glossary](#)".

1.3 Overview

This document describes the fundamental relationships and requirements that apply to several structures in a SharePoint Server implementation. It describes common object-level constraints and provides foundational requirements that explain behavior in the SharePoint family of protocols.

SharePoint Server is fundamentally divided into a set of administration objects that represent units of administration in a SharePoint implementation and a set of objects that represent content stored in the SharePoint infrastructure. Content is stored in one or more **site collections**. A site collection represents settings and data for a customer or scenario and contains a hierarchy of **sites (2)**, lists, and **folders**. Each site represents an instance of a collection used to meet a customer need—for example, a team site (2) or an Intranet portal—and contains **lists (1)**, files, and folders.

1.4 Relationship to Protocols and Other Structures

This set of data structures defines concepts and requirements to be implemented and upheld for the set of SharePoint Server protocols.

1.5 Applicability Statement

This infrastructure outlines the fundamental data structures and concepts used in the SharePoint Server protocols and it can be used for further understanding of related protocols, as well as provide additional details on restrictions used with various data structures.

1.6 Versioning and Localization

None.

1.7 Vendor-Extensible Fields

Many structures defined here can host additional data for a vendor. Sites (2), folders, **list items**, and **files** all support additional custom properties through the **metadict** infrastructure. Administration objects also support custom properties that can contain vendor-specific data. Additionally, list structures in SharePoint Server are inherently extensible, and vendors can add **fields (2)** to store custom data.

Content types can have multiple arbitrary **XML documents** associated with them. Vendors can store additional data with a content type by defining and associating their own XML documents in their own namespace.

2 Structures

This section discusses data structures that are used by protocols in the set of SharePoint Server protocols.

2.1 Abstract Data Structures

The following section describes abstract data structures and explains how dependent protocols behave in a SharePoint Server implementation. For more information about the details of this model, see [\[MSDN-SharePointSDK\]](#). This document does not mandate that implementations implement these data structures in a similar way, as long as their external behavior is consistent with the behavior described in this document and in other protocol documents about the SharePoint protocols.

2.1.1 Administration and Configuration

The administration feature of a SharePoint Server implementation contains settings that define the infrastructure and operation of a SharePoint implementation. The configuration is shown in the following diagram.

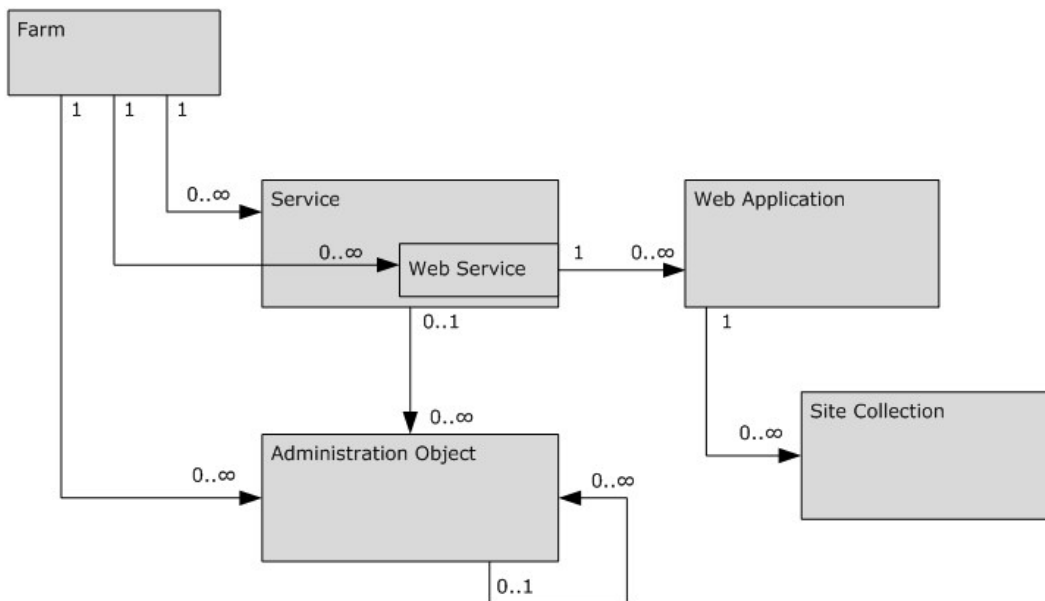

Figure 1: Overview of management and configuration data for a farm

2.1.1.1 Farm

The broadest container of a SharePoint Server protocol server is the **farm**. Any SharePoint Server protocol installation is defined by the presence of exactly one farm. A farm implementation can encompass one or more physical computers.

A farm represents a collection of administration objects (see section [2.1.1.2](#)) that function together, as well as a collection of service objects that provide centralized management of the capabilities of a farm.

One special type of service object is known as a Web service object, which specifies central settings for hosting content. A Web service object serves as the top-level container for user content that is hosted in a SharePoint Server implementation. A farm has one content Web service object and one administration Web service object. A farm also has several properties associated with it, which contain settings that apply to all objects in the farm.

2.1.1.2 Administration Object

Administration objects govern the configuration of a farm and provide object hierarchies for administering both the virtual and physical configurations of the farm.

Administration objects are defined according to an administration object type. An administration object type defines the schema for an administration object, as well as providing a set of defined operations. Administration object types define the base properties of an administration object, as well as the relationships to other administration object types, such as a parent-child relationship between administration object types.

An administration object has a **GUID** identifier.

Administration objects have additional properties that specify individual settings as defined by the administration object type, as well as a collection of additional custom properties that can be associated with the object.

Administration objects can also have a collection of child administration objects, as defined by the schema of the administration object type. An administration object has a parent administration object, unless the object is the farm.

New administration object types and instances of those administration object types can be added to the farm or to a Web service object as new subsystems are added to an implementation. For example, one administration object describes settings for antivirus scanning of content in the farm, or a hierarchy of administration objects can be used to specify document conversion settings and installed document converters.

2.1.1.3 Service

A service is a logical component that specifies a facility provided by the farm. Service facilities can be used by other components in the farm.

2.1.1.3.1 Content Web Service Object

The content Web service contains content and settings that apply to Web applications that are hosted on behalf of customers of the SharePoint Server implementation.

2.1.1.3.2 Administration Web Service Object

The administration Web service object contains content that hosts the user interface for administrators who configure the SharePoint Server infrastructure.

2.1.1.4 Web Application

A **web application (1)** contains a collection of site collections. It also contains settings for administrators that govern the usage of those site collections. A Web application is a type of administration object and inherits the object attributes and properties.

A Web application has at least one server **base URL** registered, which defines a **URL** entry point for that Web application. A Web application can have additional **alternate access mappings**, which describe additional server base URLs that can be used to access a site (2).

2.1.2 Content

Content in a SharePoint Server implementation can be expressed as a namespace hierarchy. From this perspective, a SharePoint implementation consists of folders and files that are stored hierarchically, with a root folder and descendent folders and files. Some folders in the hierarchy have associated site or list objects that define additional behavior and settings. A root site, which is paired with a root folder, has subsites and lists. Each subsite and list has one corresponding folder, as shown in the following diagram.

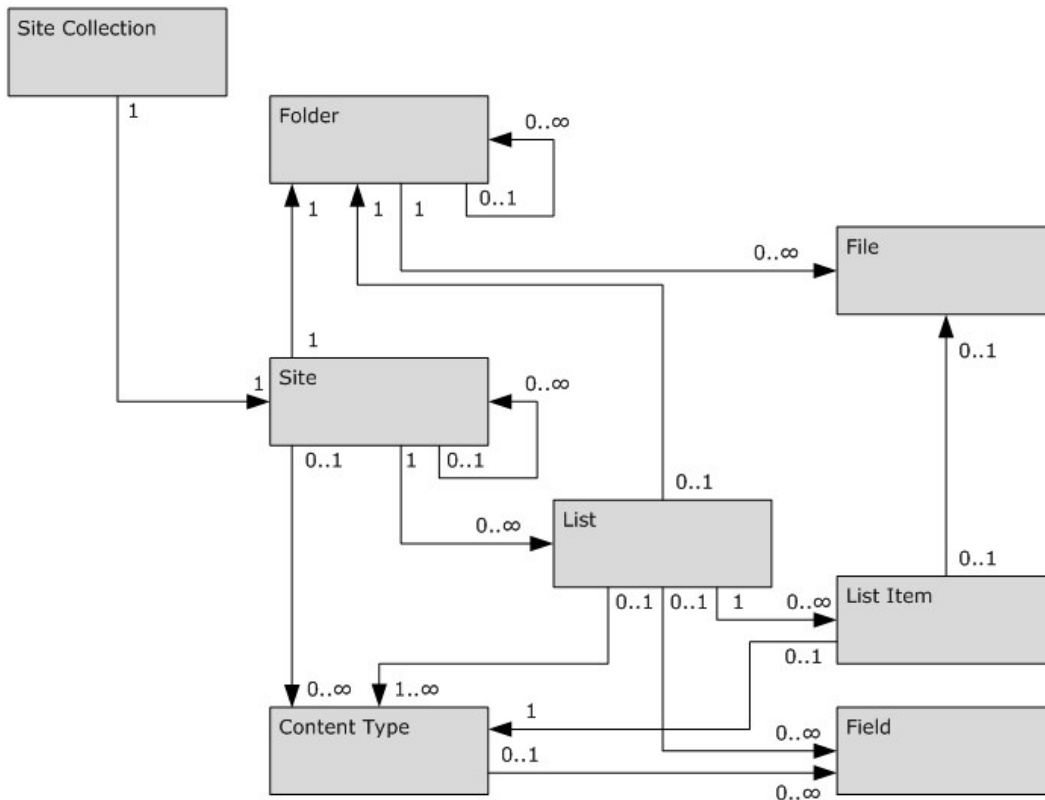

Figure 2: Overview of content data for a farm

2.1.2.1 Namespace

A namespace in a protocol server represents a hierarchy of paths that are expressed using standard URL constructs as specified in [\[RFC2396\]](#) and [\[RFC3986\]](#). Each segment in a URL is separated by a slash (/). For example, in "http://server/myfolder", there are two segments: /server and /myfolder. These segments can come from multiple sources, as follows:

- **Base server URL:** In a protocol server, the base server URL represents a URL entry point. A base server URL consists of a scheme, as well as an authority, as specified in [\[RFC2396\]](#).

- **Managed path:** Managed paths provide structures for organizing multiple site collections in a hierarchy, along with other custom content.
- **Site collection folder structure:** A site collection has a folder hierarchy that contains sites (2), lists, and folders.

2.1.2.2 Managed Path

A managed path specifies a location in a URL namespace in which new site collections can be created. Two types of managed paths are supported: explicit managed paths and wildcard managed paths.

An explicit managed path defines a set of one or more folder names, where the folder name of the leaf child node that has no child objects of its own represents the root folder of a new site collection. For example, in `http://myserver/content/site`, the explicit managed path would be `/content/site`, where *site* is the root folder of a site collection, and *content* is a folder that can have custom content associated with it.

Another type of managed path is a wildcard managed path. Every child node of the leaf in a wildcard managed path is a root folder of a SharePoint Server site collection. For example, in `http://myserver/sites/customsite`, *sites* represents the leaf for a wildcard managed path. Every child node (in this case, *customsite*) is the root folder of a site collection.

A managed path can contain other managed paths. For example, `http://myserver/content/site` might have a slash (/) as an explicit managed path and `/sites` as a wildcard managed path. If so, the slash (/) would host a site collection at the root of the server, and `/sites/customsite` would host a different site collection.

2.1.2.3 Folder

A folder is a container of other folders and files in a SharePoint Server protocol hierarchy.

A folder has a collection of files and a collection of subfolders. A folder is either the root folder of the root site in a site collection or a folder that has a parent folder.

A folder has an associated metadict (see section [2.1.2.13](#)), which contains additional properties of the folder. A list of common metadict properties is specified in [\[MS-FPSE\]](#) section 2.2.4.

A folder **MUST** also have properties that conform to the set of constraints outlined in **File System Object Constraints** (section [2.2.1](#)).

2.1.2.4 File

A file has at least one associated binary stream, which contains the contents of a file.

A file also has one associated metadict, which contains properties of the file.

A file can have an underlying template defined on the **front-end web server**. When a file has an underlying template, the file is said to be **uncustomized**, and the content of the file is not stored in the **content database**. Any change to the file "customizes" that file; that is, makes the contents of the file no longer match the template. For template-based files, a protocol server supports an operation to revert a file back to its template, that is, to reset the contents of a file back to its base version.

A file **MUST** also have properties that conform to the set of constraints outlined in **File System Object Constraints**, as specified in section [2.2.1](#).

2.1.2.5 Site Collection

A site collection describes a container of a hierarchy of sites (2). In addition, a site collection contains settings specified by the site administrator that govern the behavior of the site collection. A site collection is stored in one content database.

A site collection has flags that define the behavior of the site collection. These flags are specified in [\[MS-WSSFO3\]](#) section 2.2.2.9 .

A site collection has one root site (2). The root site (2) of a site collection can have additional settings and data that apply to all sites (2) in the site collection. The root site (2) can also contain catalogs, that is, one or more lists that function to store data and settings for the entire site collection.

2.1.2.6 Site

A site (2) represents a collection of content organized to address a consumer need.

A site (2) is created from a **site definition** or from a **site template** that contains a set of changes that are stored as a set of differences from the site definition. A site (2) has a collection of activated features, which describe additional components that extend the functionality of the site (2).

A site (2) is either the root site (2) of a site collection, or it has a parent site (2) in the same site collection. A site (2) **MUST** be associated with a folder that is a descendent of the folder associated with its parent site (2). However, there **MAY** be folders with no associated site (2) in the folder hierarchy between a site (2) and its parent site.

A site (2) has an associated folder, as specified in section [2.1.2.3](#), that defines the URL of the site (2).

A site (2) has flags and other metadata that define the behavior of the site. These flags are documented in [\[MS-WSSFO3\]](#) section 2.2.2.11.

A site (2) contains a collection of subsites and a collection of lists.

A site (2) **MUST** also have properties that conform to the set of constraints specified in Site Constraints in section [2.2.2](#).

2.1.2.7 List

A list is a container for list items. A list specifies a schema that applies to items in the list, and the schema defines a collection of fields (2) that apply to the list.

A list is derived from one list **base type** and contains all fields (2) defined by that base type. The list of base types is specified in **List Base Types**, as specified in section [2.5](#).

A list that has a base type of 1 has one file associated with every list item stored in the list. Such a list is called a **document library**. A document library has additional special semantics, which are described in **Document Library** in section [2.1.2.7.1](#).

A list is created from a list definition, as defined in section [2.1.3.2](#), which defines the underlying initial structure of fields (2), content types, forms, and views.

A list has one or more content types, as specified in section [2.1.2.8](#), which define sets of schema and behaviors for items.

A list can have a folder hierarchy, which organizes content in a list. A folder can have an associated list item, which tracks schema and behaviors. Other folders can be hidden in the list. One example is the Forms folder in a document library, which groups form pages.

A list can be connected to an external data source. This type of list is known as an external list. For an external list, all underlying data for the list is not stored in a content database, but is retrieved from an external data store using connection information defined on the protocol server. An external list is derived from the **Generic List** base type and inherits its behaviors.

A list has a collection of views, which describe filters and display preferences for viewing items in a list.

A list has a GUID, as well as a title made up of zero to 255 characters.

In addition, a list has metadata properties that define the behavior of items in the list, as well as services that are provided for the list. For example, the **Description** metadata property provides additional user-supplied text that describes the list.

Finally, a list has various settings that are determined by list flags. For a complete list of common flags, see [\[MS-WSSFO3\]](#) section 2.2.2.5.

2.1.2.7.1 Document Library

A document library is a list in which each list item has a corresponding file stored as a descendent of the document library folder; that is, each list item (section [2.1.2.10](#)) is a document (section [2.1.2.11](#)).

A document library supports optional check-in and check-out processes for documents, as well as major and minor versioning functionality for documents. See **Document Processes** (section [2.1.2.11.1](#)).

2.1.2.7.2 UserInfo List

A **UserInfo** list is a specialized type of list that tracks both basic and custom user data. Items in the **UserInfo** list are managed by the system and contain one list item for every authenticated user who has modified data on a site (2) or to whom tasks have been assigned.

The root site (2) of a site collection has its own **UserInfo** list. As in other lists, the **UserInfo** list supports adding columns.

2.1.2.8 Content Type

A content type specifies a schema and a set of behaviors for list items in a site collection. A site (2) has a collection of content types that can be applied to lists in the site (2), as well as propagated to subsites. A list has one or more associated content types that can be used for list items. A list item has only one specified content type.

A content type derives from a parent content type. The exception to this is the System Content Type (0x), which does not derive from any other content type and forms the basis of the inheritance hierarchy. Default content types are described in **Content Types** (section [2.6](#)).

A content type has a specific form of identifier that identifies not only the content type, but also its inheritance hierarchy. The structure of the **content type identifier** is described in **Content Type ID** (section [2.1.2.8.1](#)).

A content type also has a collection of XML documents that define extensions and customizations to the content type.

2.1.2.8.1 Content Type Id

The **ContentTypeId** type is the identifier for the specified content type. The identifier is a string of hexadecimal characters. The identifier MUST be unique relative to the current site collection and site (2) and MUST follow the pattern of prefixing a **ContentTypeId** with its parent **ContentTypeId**.

ContentTypeId MUST follow the XSD pattern specified in [\[MS-WSSCAML\]](#) section 2.3.1.4.

2.1.2.9 Field

A field (2) is an element of a list or **content type schema** that specifies a property that is tracked for a list item.

A field (2) has an internal name, which specifies an identifier for the field (2). A **field internal name** is unique among other fields (2) in a list and cannot contain spaces.

A field (2) has an identifier, which is a GUID.

A field (2) has a specified **field type**. A field (2) also contains state information for settings and additional metadata specified by the field type.

2.1.2.9.1 Field Type and Field Internal Type

A field type specifies the format and semantics of a field (2).

Field types specify a collection of properties that define the semantics of the field (2). For example, the text field type has a maximum length attribute that defines the maximum number of characters that the text field (2) permits.

Some properties of a field (2) relate to the behavior of the field (2) at the data level (for example, a maximum number of characters), whereas other properties are related to the visual presentation of the field (2) (for example, whether a **Choice** field (2) is displayed as radio buttons or a dropdown list).

Field types have a hierarchy. A field type can derive from another field type, from which it inherits behavior and functionality. For example, the **UserMulti** field type derives from the **LookupMulti** field type, and therefore contains semantics for working with collections of user data.

Field types that do not derive from any other field types provide the foundation of schema functionality and are referred to as **base field types**. For field types that derive from another field type, the field (2) internal type corresponds to the base field type from which the field type inherits, either directly or indirectly.

A common set of field types is specified for an implementation. These field types are specified in **Field Types** (section [2.3](#)).

2.1.2.10 List Item

A list item is a collection of related properties that define a logical object.

A list item has only one parent list. A list item contains data for fields (2) that are defined in the parent list, as well as additional custom properties that are defined through an associated metadict.

A list of common metadict properties is specified in [\[MS-FPSE\]](#) section 2.2.4. A list item also contains metadata that defines additional behavior for the list item.

A list has an item index property, which specifies a unique index for the item in relation to the list. A list item can be represented only once in its parent list.

A list item has one specified content type. A list item has one property that specifies the content type identifier of the list item. A list item supports persistence of data for additional fields (2) in a list that are not specified by the content type of the list item.

A non-document list item is associated with a base document structure that contains core data for the list item, such as the metadict of custom properties. This base document structure does not contain a file stream or URLs that correspond to reserved locations in the namespace hierarchy. If a list item is stored in a document library, the list item has a full corresponding file. This type of list item is known as a document.

A list item can have a version history if version history tracking is turned on for the parent list. A version history consists of copies of the field (2) data of the list item that are stored as users make updates to a list item.

2.1.2.11 Document

A document is a special form of list item that has an association to one file. The associated file is located in a folder hierarchy that has the folder of the parent list of the list item as an ancestor. Documents have a collection of document flags (**Doc Flags**) defined. These flags are specified in [\[MS-WSSFO3\]](#) section 2.2.2.3.

Documents have a flag that specifies the virus status of the document. This flag is specified in [\[MS-WSSFO3\]](#) section 2.2.1.2.17.

2.1.2.11.1 Document Processes

2.1.2.11.1.1 Publishing Level

A version of a document supports the following version levels:

- Published
- Draft
- Checked out

Support for draft versions is optional and configurable per library.

A protocol server tracks the publishing status of each version of a document with a **publishing level**. A published document has a **major version** number of 1 or higher and a minor version of 0. A draft document has a nonzero **minor version** number and a nonnegative major version number.

User permissions can be configured to grant some users the ability to read draft versions. Only a user who has checked out a document can read the checked-out version.

2.1.2.11.1.2 Versioning

A protocol server supports retention of multiple versions of a document over time.

In addition, an implementation supports a **current version** that differentiates which version is available to a user based on the publishing level of a document and that user's permissions.

A document under SharePoint Server version control can have as many as three versions that can be considered the current version. Which versions a user sees depends on the user's permissions, the publishing level of the document, and whether the user has the document checked out.

- A user with minimal permissions can view only the most recently published version of the document, which has a positive major version number and a minor version number of zero, if minor version numbering is enabled.
- A user with permission to see draft versions of the document can view the most recent checked-in draft version of the document. The right to see draft versions might be granted to any user who can read a document, to any user who can update a document, or only to list administrators and the user who authored the draft version, depending on the document library configuration.
- The user who has a document checked out is able to view the checked-out version, which has the next incremental version number after the most recent checked-in draft or published version.

All of these versions are considered the current version, even though only one is returned to a user as the current version when requested, depending on these criteria. Older versions are considered historical versions.

2.1.2.11.1.3 Checking In and Out

Documents support check-in and check-out operations. Checking out a document associates a user with a document and sets the publishing level of the document to checked out.

When a document is checked out, a standard item or file update operation can be performed only by the user who checked the document out. Updates to the file are not visible to other users until the document is checked in. A checked-out document can also be reverted (that is, the check-out can be reversed.) Undoing a check-out reverts the document to its state before it was last checked out.

The checked-out version can also be checked in, which promotes its publishing level to draft if draft versions are enabled, promotes its publishing level to published if moderation is not required, or signals that it is ready for approval if the system is configured to require moderation approval to mark a document as published.

Documents have a flag that indicates whether the document is in a published, draft, or checked-out state. This flag is specified in [\[MS-WSSFO3\]](#) section 2.2.2.6, Publishing Level Type.

2.1.2.11.1.4 Conversion

Documents can also support a conversion operation. Based on the file type of a file, the file can be converted to a different format. If a file is converted, a new file is created that has a link to its original source file.

2.1.2.12 Generic List Items

A generic list item is a list item that is not a document; that is, a list item that does not have a visible file associated with it. Generic list items support a loose association to additional files stored for an item, known as attachments.

Attachments stored for an item are stored in a folder in the following location for an item.

<list root folder>/Attachments/<item identifier>

In addition, a list item has an additional field (2) named Attachments, which contains a Boolean flag that expresses whether an item has one or more attachments.

2.1.2.13 Metadict

A metadict is a dictionary with strongly typed values for storing additional properties for a file, folder, or site (2). A metadict contains a collection of properties.

The normalized structure of a metadict is specified in [\[MS-FPSE\]](#) section 2.2.2.2.11. See [\[MS-FPSE\]](#) section 2.2.4 for a description of common properties.

2.1.2.14 Workflow

A workflow represents a set of actions and conditions that can be performed on a list item in response to explicit or implicit starting actions.

A workflow association contains specific workflow start and metadata information that is used to determine the operation of a workflow, as well as conditions in which a workflow runs. A workflow association can be associated with a site (2), list, or content type.

A site (2) supports a collection of workflow templates, which contain properties and references to workflow implementations.

2.1.2.14.1 Workflow Template

A workflow template contains basic metadata needed to instantiate a workflow for a list.

A workflow template has an association data property, which contains custom information for the workflow implementation. A workflow template also contains information about the content type of tasks that track workflow requirements, default workflow autostart data, and other properties.

A workflow template also has a GUID that identifies the workflow template.

2.1.2.14.2 Workflow Associations

A workflow association describes interaction between a workflow and a content type or list. It describes how a workflow starts, as well as starting behaviors and properties.

A workflow association has a GUID. It also contains a **list identifier** for a list for tracking workflow history, as well as a list identifier for a list for tracking tasks associated with workflow instances.

2.1.2.15 HTML User Interface Infrastructure

Implementations of the set of SharePoint Server protocols define mechanisms for hosting user interfaces that enable users to interact with the data that they have stored in a site collection.

2.1.2.15.1 Page

A page is a type of file that renders a user interface for users. A page can have a collection of **Web Parts**, which are user-modifiable controls that can be moved within **Web Part zones**.

2.1.2.15.2 Web Part

A Web Part instance is a single component that resides on a page and can display data, visualizations, or some form of user interface. A connection is defined as a relationship between two Web Parts that are an agreed-upon interface, as well as additional metadata that corresponds to that connection. A Web Part can have zero or more connections to other Web Parts on the page.

A Web Part supports zero or more properties that can be modified to change how the Web Part behaves or renders. There are two groups of properties: those that can be customized and those that can be personalized. A property can be customized if all users who access the Web Part get the same value for the property. A property can be personalized if users who access the Web Part can modify the property to a value specific to each user.

2.1.2.15.3 View

A view is a description of a visualization of a list. A list supports a collection of views. A view has one associated Web Part instance (the view Web Part). Because a Web Part instance exists in the context of a page, a view therefore has an associated page.

A view has a collection of settings flags defined. These flags are specified in [\[MS-WSSFO3\]](#) section 2.2.2.13.

2.1.2.15.4 Form

A form provides a display and editing interface for a single list item. A form has one associated Web Part instance (a form Web Part). Because a Web Part instance exists in the context of a page, a form has an associated page.

A form has a collection of setting flags defined. These flags are specified in [\[MS-WSSFO3\]](#) section 2.2.3.13.

2.1.2.16 Navigation Structure

The **Navigation** structure is a hierarchical representation of some or all files (see section [2.1.2.4](#)) and folders (see section [2.1.2.3](#)) in the site collection, as well as their literal URL strings. Each element in the hierarchy is a **navigation node**. The purpose of the **Navigation** structure is to provide a way to define and render links to related URLs.

Every site (2) has one associated **Navigation** structure. The **Navigation** structure has one navigation node whose **navigation node element identifier** is zero. This is the root node of the hierarchical structure.

2.1.2.16.1 Navigation Nodes

There are two types of navigation nodes: type zero and type 1.

Type zero navigation nodes link to files or folders in the site collection that contains the site (2). These are automatically made visible or hidden when rendering the links, based on whether the files or folders are accessible to the user. Also, any changes to the URL of the file or folder are updated automatically for this type of navigation node. The navigation structure of a site (2) can only have one type zero navigation node pointing to a file or folder, unless the navigation node has its **ChildOfLinkBar** property set to 1.

Type 1 navigation nodes link to literal URL strings. A literal URL can point to files or folders in the site collection that contains the site (2), such as type zero navigation nodes, but they are treated as

literal URLs to external Web sites and do not get the automatic behaviors described earlier for type zero navigation nodes.

Navigation nodes have the following properties that distinguish their behavior.

LinkBar: A navigation node that has this property set to 1 defines a set of related navigation nodes. Only type 1 navigation nodes can have this property set to 1. Child objects of such a navigation node can be of either type zero or type 1, and they have the **ChildOfLinkBar** property set to 1.

ChildOfLinkBar: This property is set to 1 for any navigation node whose parent has the **LinkBar** property set to 1.

NonNavPage: If this property is set to 1 on a navigation node, it is hidden when rendering the navigation node [<1>](#).

Navigation nodes can be created as part of site creation by specifying them in the site definition. Navigation nodes can be added, moved, or deleted later by a user who has the required permissions.

2.1.2.16.2 Navigation Node Identifiers

Each navigation node has a navigation node element identifier.

The following restrictions are enforced when using navigation node element identifiers:

- Navigation node element identifiers from zero through 999 are reserved and are used only as temporary values for adding new navigation nodes to the navigation structure. This identifier is translated to a valid value greater than 2000 when performing the add operation.
- Navigation node element identifiers from 1000 to 2000 can be used only to create navigation nodes from the site definition [<2>](#).

2.1.3 Provisioning Data Structures

2.1.3.1 Site Definition

A site definition specifies settings that are used when a new site (2) is created, as well as a set of features to activate. The structure of a site definition is specific to the implementation of the protocol server.

A site definition can contain the following:

- A set of pre-defined files to be provisioned.
- References to zero or more features that contain additional functionality for the site (2).

A site definition has a template identifier, which is an integer.

2.1.3.2 List Definition

A list definition specifies settings that are used when a new list is created. The structure of a list definition is specific to the implementation of the protocol server.

A list definition can contain the following:

- A set of pre-defined files to be provisioned.

- Field (2) definitions.
- Associated content type references.
- View definitions.
- Form definitions.

A list definition has an integer template identifier. A list definition can have a feature identifier, which specifies the feature that contains the list definition. If a list definition is defined for a feature and has a feature identifier, the scope of the containing feature MUST be set to "Web" or "Site".

2.1.3.3 Feature

A feature is a structured modular component that enables built-in or user-defined classes, objects, and definitions that extend the front-end web server.

Features have the following attributes:

Scope: Specifies how the feature applies to a site (2). A feature is scoped to one of the entities described in the following table.

Value	Description
Farm	Specifies that the elements of the feature apply to the entire farm, if the feature is activated.
Web Application	Specifies that the elements of the feature apply only to Web applications that have the feature activated.
Site	Specifies that the elements of the feature apply only to site collections that have the feature activated.
Web	Specifies that the elements of the feature apply only to sites (2) that have the feature activated.

Id: A GUID that identifies the feature.

2.1.4 Authentication and Security

A farm supports interoperability with at least one authentication system. The authentication system provides details on lists of users that are available to the farm and can also provide groupings of users. The authentication system is also responsible for requesting credentials from incoming users to identify and validate them.

A site collection in a farm can support users from one or more authentication systems.

2.1.4.1 Authentication System

An authentication system has a collection of authentication system users. An authentication system can also have a named group of authentication system users created to facilitate treating a set of users as a unit. These groups specify a list of users that belong to the group. The group also has an identifier.

2.1.4.1.1 Authentication System User

An authentication system user has the following attributes:

Id: A consistent **SystemID** of the authentication system user that identifies the user.

Name: A name for the user.

2.1.4.1.2 Authentication System Group

An authentication system group has the following attributes:

Id: Specifies a consistent identifier of the authentication system group.

Name: A name for the group.

2.1.4.2 Principal

A **principal (1)** represents either a single user or a group of users in the authentication system.

A principal (1) has a unique identifier that defines the principal (1). In a site (2), a principal (1) also has a unique integer identifier that identifies the principal (1) in that site (2).

2.1.4.3 Group

A site collection supports a collection of **groups (2)**. A group is a list of named principals (1). A group can be assigned one or more roles, or given permissions explicitly, or both.

2.1.4.4 Securable Object

A **securable object** is an object that can have unique or inherited permissions.

A protocol server implementation supports sites (2), lists, folders, and list items as securable objects. Additionally, files and folders associated with list items in a list are supported as securable objects. A Forms folder in a list has the same permissions as its containing list. An attachment file or a thumbnail file has the same permissions as the respective list item.

A file or folder outside a library has the same permissions as its containing site.

2.1.4.5 Scope

A scope involves one or more nodes in the data hierarchy of protocol server sites (2), lists, folders, and list items that share the same set of permissions. A scope applies to hierarchical elements from only one site collection. If a node in the hierarchy of securable objects has the same scope as its parent (for example, a list that has the same scope as its parent site), that node is said to inherit the permissions of its parent. A child securable object has separate permissions from its parent if it has a different scope.

A scope has an associated collection of assignments of principals (1) or groups to roles or explicit permissions known as an **access control list (ACL)**.

A scope is identified by GUID.

2.1.4.6 Permission

A permission is a specific named right for a particular action or behavior. Permissions can be applicable to list items, folders, or sites (2). The set of rights is specified in the WSS Rights Mask structure in [\[MS-WSSFO3\]](#) section 2.2.2.15. For example, the **ViewListItems** right enables the specified user to view list items in a list.

2.1.4.7 Read My Own, Write My Own

In addition to right- and role-based security, a list also has flags that enable a list to have either "read my own", or "write my own" security, or both. If a list has "read my own" security, users of a list can see only items that they have created. If a list has "write my own" security, users of a list can edit only items that they have created. A user with Manage List permissions can read items irrespective of **Read My Own** or **Write My Own** flags.

2.1.4.8 Role Definition

A **role definition** is a collection of named rights. A role definition can be assigned directly to a principal (1) or to a group.

2.2 Object-Level Constraints and Requirements

2.2.1 File System Object Constraints

A file system object is either a folder or a file.

A file system object **MUST** have a name between 1 and 128 characters in length that expresses the location of the file system object in the hierarchy.

A file system object name **MUST NOT** contain any of the following characters:

- ~
- #
- %
- &
- *
- { }
- \
- :
- < >
- ?
- /
- |
- "

A file system object name **MUST NOT** begin or end with a period. A file system object name **MUST** not contain consecutive periods. A file system object name **MUST NOT** begin with leading whitespaces or end with trailing whitespaces as defined by the following: `character = 0x20` or `character > 0x09` and `character <= 0x0D`.

2.2.2 Site Constraints

A site (2) MUST have a name property with the same fundamental constraints as its corresponding folder name. All restrictions of the folder name apply to the site name. In addition, the following constraints apply to site names only:

- They MUST NOT begin with an underscore (_) character.
- They MUST NOT begin with a period (.) character.
- They MUST NOT contain a quotation mark (") character.
- They MUST NOT contain characters less than 0x20.

A site (2) has a **Title** property that provides a friendly name for the site. The site **Title** can be from 1 through 255 characters in length.

2.3 Field Types

2.3.1 Base Field Types

The following table describes the field types that are defined and used by the base types of a protocol server.

Field type name	Description
AllDayEvent	This field type is used only in conjunction with an Events list. TRUE if the item is an all-day event (that is, does not occur during a specific set of hours in a day).
Attachments	This field type describes whether one or more files are associated with the item. See Attachments in Base Data Fields (section 2.4.2) for more information about attachments. TRUE if a list item has attachments, and FALSE if a list item does not have attachments.
Boolean	This field type can be set to TRUE or FALSE.
Calculated	This field type value is calculated based on the value of other columns.
Choice	This field type enables selection from a set of suggested values. A property on a choice field (2) specifies whether values other than the suggested values are supported.
Computed	This field type renders output based on the value of other columns.
ContentTypeId	This field type contains a content type identifier for an item. ContentTypeId conforms to the structure defined in Content Type Id (section 2.1.2.8.1).
Counter	This field type is a monotonically increasing integer field (2) that has a unique value in relation to other values stored for the field (2) in the list. This field (2) is used only for the list item identifier field (2), and not intended for use elsewhere.
CrossProjectLink	This field type enables a link to a Meeting Workspace site .
Currency	This field type provides for currency-related data. This field (2) has a CurrencyLocaleId property that takes the locale identifier of the desired currency.
DateTime	This field type enables full date and time values, as well as date-only values.

Field type name	Description
Error	Specifies errors.
File	Specifies a reference to a file to retrieve the contents of that file.
GridChoice	This field type enables specification of multiple number scales in a list.
Geolocation	This field type accepts location by longitude, latitude, and possibly altitude.
Guid	Specifies that the value of the field (2) is a GUID.
Integer	This field type accepts an integer value.
Invalid	Field type is not specified.
Lookup	This field type enables a reference to another list item. It enables specification of a list identifier for a targeted list. An optional site identifier can also be specified, which specifies the site (2) of the list that contains the target of the lookup field .
MaxItems	Specifies the maximum number of items.
ModStat	Specifies the current status of a moderation process on the document. Value corresponds to one of the moderation status values specified in [MS-WSSFO3] section 2.2.4.13.
MultiChoice	This field type accepts one or more values from a set of specified choices. This field (2) also accepts free-form values.
Note	This field type accepts a string of text, which can be longer than a Text field (2).
Number	This field type accepts a positive or negative number. A number field (2) supports a setting at the field (2) level that specifies the number of decimal places to display.
PageSeparator	Represents a placeholder for a page separator in a survey list. This field type is intended to be used only with a survey list.
Recurrence	Specifies a field (2) that is used to display recurring events. As with a computed field , this field type is an abstract field type that depends on other fields (2) for its content and definition. It is intended to be used only with an events list.
Text	This field type accepts a string of text up to 255 characters in length.
Threading	Contains data on the threading of items in a discussion board.
ThreadIndex	Contains a compiled index of threads in a discussion board.
User	A lookup field to a user in the User Info list.
URL	This field type accepts a URL and an optional description of the URL.
WorkflowEventType	A description of a type of a historical workflow event. See WorkflowEventType Enumeration (section 2.8.1) for more information.
WorkflowStatus	Contains status on a running workflow for an item. See WorkflowStatus (section 2.8.2) for more details.

2.3.2 Extended Field Types

The extended field types are specified in the following table.

Field type name	Description
LookupMulti	Enables entry and storage of multiple values for lookup fields to list items from a specified list.
UserMulti	Enables entry and storage of multiple values for lookup fields to a collection of users.

2.4 Common Fields

2.4.1 Document Lookup

In the following table, some fields (2) are expressed in the form of a document lookup field to a particular data type. A document lookup field is a special case of a lookup field. As in all lookup fields, a document lookup field is expressed in the form "<item id>;#<value>". However, for a document lookup field, the item ID of the item is used, rather than the item ID of the target of the lookup field. The form of a lookup field is defined as follows.

```
SEMICOLONPOUND = " ;#"
ITEMID = 1*DIGIT ; identifier of the item
VALUE = *CHAR ; value of the item
LOOKUP = ITEMID SEMICOLONPOUND VALUE
```

2.4.2 Base Data Fields

A protocol server supports the fields (2) and identifiers described in the following table.

Field name	ID	Type	Description
_CheckinComment	{58014f77-5463-437b-ab67-eec79532da67}	Document Lookup to string	Last comment from a check-in of the document.
_CopySource	{6b4e226d-3d88-4a36-808d-a129bf52bccf}	Text	Contains a URL of the source list item from which this item was created, if the item was created as a result of a copy operation.
_HasCopyDestinations	{26d0756c-986a-48a7-af35-bf18ab85ff4a}	Boolean	Specifies whether a list item has multiple stored locations to which data is to be copied when the item is updated.
_IsCurrentVersion	{c101c3e7-122d-4d4d-bc34-58e94a38c816}	Boolean	Specifies whether the data represents an appropriate current version or a historical item.

Field name	ID	Type	Description
_Level	{43bdd51b-3c5b-4e78-90a8-fb2087f71e70}	Integer	Specifies an integer that represents the publishing level of the document.
_ModerationComments	{34ad21eb-75bd-4544-8c73-0e08330291fe}	Note	Contains comments from the last moderation action.
_ModerationStatus	{fdc3b2ed-5bf2-4835-a4bc-b885f3396a61}	ModStat	Current moderation status of an item. See [MS-WSSFO3] section 2.2.4.13 for a description of values.
_SourceUrl	{c63a459d-54ba-4ab7-933a-dcf1c6fadec2}	Text	Contains an absolute URL to the source document for a Document Workspace site item.
_SharedFileIndex	{034998e9-bf1c-4288-bbbd-00eacfc64410}	Text	Contains an identifier of the Document Workspace site used to manage sharing of this document.
_UIVersion	{7841bf41-43d0-4434-9f50-a673baef7631}	Integer	A single 4-byte integer that contains user interface (UI) version information. The lower 9 bits correspond to the minor version number of the displayed version, and the remaining 23 bits refer to the major version number. For example, a document with a displayed version number of 4.7 would have a UI version value of $(4 * 512) + 7 = 2055$.
_UIVersionString	{dce8262a-3ae9-45aa-aab4-83bd75fb738a}	Text	Contains a displayable string with the version of the item.
Attachments	{67df98f4-9dec-48ff-a553-29bece9c5bf4}	Attachments	Specifies whether the list item has attachments.
Author	{1df5e554-ec7e-46a6-901d-d85a3881cb18}	User	Identifier of the user who created the item.
BaseName	{7615464b-559e-4302-b8e2-8f440b913101}	Computed	Name of the file, without a file type extension.

Field name	ID	Type	Description
ContentType	{c042a256-787d-4a6f-8a8a-cf6ab767f12d}	Text	Name of the content type associated with the item.
ContentTypeId	{03e45e84-1992-4d42-9116-26f756012634}	ContentTypeId	Content type identifier of the item. MUST be a valid content type identifier for the content type of the item.
Created	{8c06beca-0777-48f7-91c7-6da68bc07b69}	DateTime	Date and time at which the item was created.
Created_x0020_Date	{998b5cff-4a35-47a7-92f3-3914aa6aa4a2}	Document Lookup to DateTime	Date and time at which a related file was created.
Editor	{d31655d1-1d5b-4511-95a1-7a09e9b75bf2}	User	Identifier and name of the user who last edited a document.
File_x0020_Size	{8fca95c0-9b7d-456f-8dae-b41ee2728b85}	Document lookup to integer	Size, in bytes, of the file.
File_x0020_Type	{39360f11-34cf-4356-9945-25c44e68dade}	Text	Extension of the related file of an item.
FileDirRef	{56605df6-8fa1-47e4-a04c-5b384d59609f}	Document Lookup to Text	A store-relative URL of the directory name that contains the related file of an item.
FileLeafRef	{8553196d-ec8d-4564-9861-3dbe931050c8}	File	Name of the file associated with the item. This type contains only the name of the file. It does not contain the URL structure of parent folders of the file.
FileRef	{94f89715-e097-4e8b-ba79-ea02aa8b7adb}	Document Lookup to String	A server-relative URL of the full path of the item's related file.
FSObjType	{30bb605f-5bae-48fe-b4e3-1f81d9772af9}	Document Lookup to Integer	A lookup field to the type of object. See [MS-WSSFO3], 2.2.3.4 for possible values.
GUID	{ae069f25-3ac2-4256-b9c3-15dbc15da0e0}	Guid	Specifies a user-customizable unique identifier of an item.
HTML_x0020_File_x0020_Type	Differs according to the base type. See HTML_x0020_File_x0020_Type in each section of List Base Types	Differs according to the base type. See HTML_x0020_File_x0020_Type in each section of List Base Types	Differs according to the base type. See HTML_x0020_File_x0020_Type in each section of List Base Types

Field name	ID	Type	Description
	(section 2.5).	(section 2.5).	(section 2.5).
ID	{1d22ea11-1e32-424e-89ab-9fedbadb6ce1}	Counter	Numeric identifier of the item. This field (2) is unique in the parent list.
InstanceID	{50a54da4-1528-4e67-954a-e2d24f1e9efb}	Integer	Contains an identifier of a meeting instance for this item.
Last_x0020_Modified	{173f76c8-aebd-446a-9bc9-769a2bd2c18f}	Document Lookup to DateTime	Lookup to the last modified time of the related file of the item.
MetaInfo	{687c7f94-686a-42d3-9b67-2782eac4b4f8}	Document Lookup to String	A metadict that contains additional properties for the item.
Modified	{28cf69c5-fa48-462a-b5cd-27b6f9d2bd5f}	DateTime	Date and time of the last modification to the item.
Order	{ca4addac-796f-4b23-b093-d2a3f65c0774}	Number	Number used to establish the order of a list item relative to other list items in the list.
owshiddenversion	{d4e44a66-ee3a-4d02-88c9-4ec5ff3f4cd5}	Integer	Monotonically increasing integer representation of the last change to an item.
ParentVersionString	{BC1A8EFB-0F4C-49f8-A38F-7FE22AF3D3E0}	Document Lookup to String	Contains a lookup field to the UIVersion of the parent file of a converted or transformed file. See Conversion (section 2.1.2.11.1.4) for more information about file conversion.
ParentLeafName	{774EAB3A-855F-4a34-99DA-69DC21043BEC}	Document Lookup to String	Contains a lookup field to the file name of a parent file of a converted or transformed file. See Conversion (section 2.1.2.11.1.4) for more information about file conversion.
PermMask	{BA3C27EE-4791-4867-8821-FF99000BAC98}	Computed	Contains the set of permissions of an item for a user who requests the item.

Field name	ID	Type	Description
ProgId	{c5c4b81c-f1d9-4b43-a6a2-090df32ebb68}	Document Lookup to String	A lookup field to the identifier of a client application that can be used to edit this document.
ScopeId	{ddd2420-b270-4735-93b5-92b713d0944d}	Document Lookup to String	Identifier of the security scope to which this item belongs.
ServerUrl	{105f76ce-724a-4bba-aece-f81f2fce58f5}	Computed	Server-relative URL of a file for this item.
Title	Differs according to the base type. See Title in each "Data Fields" subsection of section 2.5 .	Text	Specifies a description of the list item.
UniqueId	{4b7403de-8d94-43e8-9f0f-137a3e298126}	Document Lookup to GUID	Lookup to a GUID for an item.
VirusStatus	{4a389cb9-54dd-4287-a71a-90ff362028bc}	Document Lookup to Integer	Integer value that specifies the current virus-checking status of the file. See [MS-WSSFO3] section 2.2.3.15 for more information.
WorkflowInstanceID	{de8beacf-5505-47cd-80a6-aa44e7ffe2f4}	Guid	Specifies the identifier of a workflow instance currently associated with a list item.
WorkflowVersion	{f1e020bc-ba26-443f-bf2f-b68715017bbc}	Integer	Specifies the version of the workflow instance running for a particular item.

2.4.3 Base Rendering Fields

These fields (2) define a set of computed fields that render HTML for list views and forms.

Field name	ID	Type	Description
_EditMenuTableEnd	{2ea78cef-1bf9-4019-960a-02c41636cb47}	Computed	Contains an HTML rendering of the end of an edit menu
_EditMenuTableStart	{3c6303be-e21f-4366-80d7-d6d0a3b22c7a}	Computed	Contains an HTML rendering of the beginning of an edit menu.
DocIcon	{081c6e4c-5c14-4f20-b23e-1a71ceb6a67c}	Computed	String that represents HTML that can display a document icon.
Edit	{503f1caa-358e-4918-9094-4a2cdc4bc034}	Computed	Contains an icon-based link to an edit form for this item.

Field name	ID	Type	Description
EncodedAbsUrl	{7177cfc7-f399-4d4d-905d-37dd51bc90bf}	Computed	Absolute server-relative URL of the related file of an item.
FileSizeDisplay	{78a07ba4-bda8-4357-9e0f-580d64487583}	Computed	Contains a representation of the file size, in kilobytes.
LinkFilename	{5cc6dc79-3710-4374-b433-61cb4a686c12}	Computed	HTML rendition of the name of the item's related file.
LinkFilenameNoMenu	{9d30f126-ba48-446b-b8f9-83745f322ebe}	Computed	HTML rendition of the name of the item's related file.
LinkTitle	{82642ec8-ef9b-478f-acf9-31f7d45fbc31}	Computed	Specifies an HTML rendering of the item, which is used in links with an additional menu of options.
LinkTitleNoMenu	{bc91a437-52e7-49e1-8c4e-4698904b2b6d}	Computed	Specifies an HTML rendering of the item.
SelectFilename	{5f47e085-2150-41dc-b661-442f3027f552}	Computed	Specifies the file name of a document library that can be used in the user interface to select a file version.
SelectTitle	{b1f7969b-ea65-42e1-8b54-b588292635f2}	Computed	Specifies a title field (2) of a list that can be used to select an item version in the user interface.

2.4.4 XML Document Data Fields

A protocol server also supports the following fields (2) which are used in a form library.

Field name	ID	Type	Description
TemplateUrl	{4B1BF6C6-4F39-45ac-ACD5-16FE7A214E5E}	Text	Contains a URL link to a template file that is used to create an XML file.
xd_ProgID	{CD1ECB9F-DD4E-4f29-AB9E-E9FF40048D64}	Text	Specifies a field (2) for data that contains the identifier of a preferred client application for XML files.
xd_Signature	{FBF29B2D-CAE5-49aa-8E0A-29955B540122}	Boolean	Specifies an XML Path Language (XPath) used to find a digital signature in a document.

2.4.5 XML Document Rendering Fields

This is a set of computed fields that render HTML for form libraries.

Field name	ID	Type	Description
Combine	{E52012A0-51EB-4c0c-8DFB-9B8A0EBEDCB6}	Computed	Includes an HTML user interface for selecting a document to combine.
RepairDocument	{5D36727B-BCB2-47d2-A231-1F0BC63B7439}	Computed	Includes an HTML user interface for selecting a document for repair.

2.4.6 Survey Data Fields

The survey data fields are specified in the following table.

Field name	ID	Type	Description
Completed	{35363960-D998-4aad-B7E8-058DFE2C669E}	Computed	Boolean that specifies whether the survey item is finished.

2.5 List Base Types

A list has one specified base type, which is one of values in the following table.

Base type name	Value
Generic List	0
Document Library	1
Discussion Board	3
Survey	4
Issue	5

An implementation SHOULD NOT have a list with a base type of 3 <3>.

A list item has associated fields (2) that are specified in the following sections.

2.5.1 Common List Item Fields

These fields (2) are common to all list items, irrespective of base type.

2.5.1.1 Data Fields

Field name	Field ID
_CopySource	{6b4e226d-3d88-4a36-808d-a129bf52bccf}
_HasCopyDestinations	{26d0756c-986a-48a7-af35-bf18ab85ff4a}
_IsCurrentVersion	{c101c3e7-122d-4d4d-bc34-58e94a38c816}
_Level	{43bdd51b-3c5b-4e78-90a8-fb2087f71e70}
_ModerationStatus	{fdc3b2ed-5bf2-4835-a4bc-b885f3396a61}
_UIVersion	{7841bf41-43d0-4434-9f50-a673baef7631}
_UIVersionString	{dce8262a-3ae9-45aa-aab4-83bd75fb738a}
Author	{1df5e554-ec7e-46a6-901d-d85a3881cb18}
BaseName	{7615464b-559e-4302-b8e2-8f440b913101}
ContentType	{c042a256-787d-4a6f-8a8a-cf6ab767f12d}

Field name	Field ID
ContentTypeId	{03e45e84-1992-4d42-9116-26f756012634}
Created	{8c06beca-0777-48f7-91c7-6da68bc07b69}
Created_x0020_Date	{998b5cff-4a35-47a7-92f3-3914aa6aa4a2}
Editor	{d31655d1-1d5b-4511-95a1-7a09e9b75bf2}
EncodedAbsUrl	{7177cfc7-f399-4d4d-905d-37dd51bc90bf}
File_x0020_Type	{39360f11-34cf-4356-9945-25c44e68dade}
FileDirRef	{56605df6-8fa1-47e4-a04c-5b384d59609f}
FileLeafRef	{8553196d-ec8d-4564-9861-3dbe931050c8}
FileRef	{94f89715-e097-4e8b-ba79-ea02aa8b7adb}
FolderChildCount<4>	{960ff01f-2b6d-4f1b-9c3f-e19ad8927341}
FSObjType	{30bb605f-5bae-48fe-b4e3-1f81d9772af9}
ID	{1d22ea11-1e32-424e-89ab-9fedbadb6ce1}
InstanceID	{50a54da4-1528-4e67-954a-e2d24f1e9efb}
ItemChildCount<5>	{b824e17e-a1b3-426e-aecf-f0184d900485}
Last_x0020_Modified	{173f76c8-aebd-446a-9bc9-769a2bd2c18f}
MetaInfo	{687c7f94-686a-42d3-9b67-2782eac4b4f8}
Modified	{28cf69c5-fa48-462a-b5cd-27b6f9d2bd5f}
Order	{ca4addac-796f-4b23-b093-d2a3f65c0774}
owshiddenversion	{d4e44a66-ee3a-4d02-88c9-4ec5ff3f4cd5}
PermMask	{BA3C27EE-4791-4867-8821-FF99000BAC98}
ProgId	{c5c4b81c-f1d9-4b43-a6a2-090df32ebb68}
ScopeId	{ddd2420-b270-4735-93b5-92b713d0944d}
ServerUrl	{105f76ce-724a-4bba-aece-f81f2fce58f5}
SortBehavior<6>	{423874f8-c300-4bfb-b7a1-42e2159e3b19}
SyncClientId<7>	{6d2c4fde-3605-428e-a236-ce5f3dc2b4d4}
UniqueId	{4b7403de-8d94-43e8-9f0f-137a3e298126}

2.5.1.2 HTML Rendering Fields

HTML rendering fields (2) provide views, in HTML, for data in a list item. HTML rendering fields (2) are specific to the user interface implementation, and instances of these fields (2) in a list item do not contain underlying data.

Field name	Field ID
_EditMenuTableEnd	{2ea78cef-1bf9-4019-960a-02c41636cb47}
_EditMenuTableStart	{3c6303be-e21f-4366-80d7-d6d0a3b22c7a}
_EditMenuTableStart2<8>	{1344423c-c7f9-4134-88e4-ad842e2d723c}
DocIcon	{081c6e4c-5c14-4f20-b23e-1a71ceb6a67c}
LinkFilename	{5cc6dc79-3710-4374-b433-61cb4a686c12}
LinkFilename2<9>	{224ba411-da77-4050-b0eb-62d422f13d3e}
LinkFilenameNoMenu	{9d30f126-ba48-446b-b8f9-83745f322ebe}

2.5.2 Generic List

This base type is the foundation for custom lists that are not document libraries.

Custom list items contain fields (2) from the following table, in addition to those from the common list item field (2) set.

2.5.2.1 Data Fields

Field name	Field ID
_ModerationComments	{34ad21eb-75bd-4544-8c73-0e08330291fe}
Attachments	{67df98f4-9dec-48ff-a553-29bece9c5bf4}.
GUID	{ae069f25-3ac2-4256-b9c3-15dbc15da0e0}
HTML_x0020_File_x0020_Type	{4ef1b78f-fdba-48dc-b8ab-3fa06a0c9804}
Title	{fa564e0f-0c70-4ab9-b863-0177e6ddd247}
WorkflowInstanceID	{de8beacf-5505-47cd-80a6-aa44e7ffe2f4}
WorkflowVersion	{f1e020bc-ba26-443f-bf2f-b68715017bbc}

2.5.2.2 HTML Rendering Fields

HTML rendering fields (2) provide views, in HTML, for data in a list item. HTML rendering fields (2) are specific to the user interface implementation and instances of these fields (2) in a list item do not contain underlying data.

Field name	Field ID
Edit	{503f1caa-358e-4918-9094-4a2cdc4bc034}
LinkTitle	{82642ec8-ef9b-478f-acf9-31f7d45fbc31}
LinkTitle2<10>	{5f190d91-3dbc-4489-9878-3c092caf35b6}
LinkTitleNoMenu	{bc91a437-52e7-49e1-8c4e-4698904b2b6d}

Field name	Field ID
SelectTitle	{b1f7969b-ea65-42e1-8b54-b588292635f2}

2.5.3 Document

This base type serves as the foundation for any document type, and any document library.

2.5.3.1 Data Fields

Field name	Field type	Field ID/Description
_CheckinComment	Lookup	{58014f77-5463-437b-ab67-eec79532da67}
_ModerationComments	Note	{34ad21eb-75bd-4544-8c73-0e08330291fe}
_SharedFileIndex	Text	{034998e9-bf1c-4288-bbbd-00eacfc64410}
_SourceUrl	Text	{c63a459d-54ba-4ab7-933a-dcf1c6fadec2}
CheckedOutTitle	Lookup	Obsolete. A protocol client SHOULD ignore this value.
CheckedOutUserId	Lookup	{a7b731a3-1df1-4d74-a5c6-e2efba617ae2} User identifier of the user who has checked out a document.
CheckoutUser	User	{3881510a-4e4a-4ee8-b102-8ee8e2d0dd4b}
Created_x0020_By	Text	{4dd7e525-8d6b-4cb4-9d3e-44ee25f973eb}
DocConcurrencyNumber<11>	Lookup	{8e69e8e8-df8a-45dc-858a-1b806dde24c0}
File_x0020_Size	Lookup	{8fca95c0-9b7d-456f-8dae-b41ee2728b85}
GUID	Guid	{ae069f25-3ac2-4256-b9c3-15dbc15da0e0} Specifies a unique identifier for the document.
HTML_x0020_File_x0020_Type	Text	{0c5e0085-eb30-494b-9cdd-ec1d3c649a2} Contains a ProgID of a client application for HTML- and XML-based files.
IsCheckedoutToLocal	Lookup	{cfaabd0f-bdbd-4bc2-b375-1e779e2cad08} Specifies whether the file is checked out to a local copy of the file.
Modified_x0020_By	Text	{822c78e3-1ea9-4943-b449-57863ad33ca9}
ParentLeafName	Lookup	{774EAB3A-855F-4a34-99DA-69DC21043BEC}
ParentVersionString	Lookup	{BC1A8EFB-0F4C-49f8-A38F-7FE22AF3D3E0}
Title	Text	{fa564e0f-0c70-4ab9-b863-0177e6ddd247}
TemplateUrl	Text	{4b1bf6c6-4f39-45ac-acd5-16fe7a214e5e}
VirusStatus	Lookup	{4a389cb9-54dd-4287-a71a-90ff362028bc}

Field name	Field type	Field ID/Description
WorkflowInstanceID	Guid	{de8beacf-5505-47cd-80a6-aa44e7ffe2f4}
WorkflowVersion	Integer	{f1e020bc-ba26-443f-bf2f-b68715017bbc}
xd_ProgID	Text	{cd1ecb9f-dd4e-4f29-ab9e-e9ff40048d64}
xd_Signature	Boolean	{fbf29b2d-cae5-49aa-8e0a-29955b540122}

2.5.3.2 HTML Rendering Fields

HTML rendering fields (2) provide specific views, in HTML, for data in a list item. HTML rendering fields (2) are specific to the user interface implementation, and instances of these fields (2) in a list item do not contain underlying data.

Field name	Field type	Field ID or description
Combine	Computed	{e52012a0-51eb-4c0c-8dfb-9b8a0ebedcb6}
Edit	Computed	{503f1caa-358e-4918-9094-4a2cdc4bc034}
FileSizeDisplay	Computed	{78a07ba4-bda8-4357-9e0f-580d64487583}
LinkCheckedOutTitle	Computed	Obsolete. A protocol client SHOULD ignore this value.
RepairDocument	Computed	{5d36727b-bcb2-47d2-a231-1f0bc63b7439}
SelectFilename	Computed	{5f47e085-2150-41dc-b661-442f3027f552}
SelectTitle	Computed	{b1f7969b-ea65-42e1-8b54-b588292635f2}

2.5.4 Discussion Board

Specifies the base type of a discussion board. This base type is obsolete. Implementations of discussion boards SHOULD implement discussion boards using the pattern of the Discussion Board list, which is based on the base type specified in **Generic List** (section [2.5.2](#))<12>.

2.5.4.1 Data Fields

Field name	Type	Field ID or description
_ModerationComments	Note	{34ad21eb-75bd-4544-8c73-0e08330291fe}
Attachments	Attachments	{67df98f4-9dec-48ff-a553-29bece9c5bf4}.
Body	Note	Contains the body of the item. ID: {7662cd2c-f069-4dba-9e35-082cf976e170}
GUID	Guid	{ae069f25-3ac2-4256-b9c3-15dbc15da0e0}
Title	Text	{fa564e0f-0c70-4ab9-b863-0177e6ddd247}

2.5.4.2 HTML Rendering Fields

HTML rendering fields (2) provide views, in HTML, for data in a list item. HTML rendering fields (2) are specific to the user interface implementation, and instances of these fields (2) in a list item do not contain underlying data.

Field name	Type	Field ID or description
BodyAndMore	Computed	{c7e9537e-bde4-4923-a100-adbd9e0a0a0d}
BodyWasExpanded	Computed	{af82aa75-3039-4573-84a8-73ffdfd22733}
CorrectBodyToShow	Computed	{b0204f69-2253-43d2-99ad-c0df00031b66}
DiscussionTitle	Computed	{c5abfdc7-3435-4183-9207-3d1146895cf8}
Edit	Computed	{503f1caa-358e-4918-9094-4a2cdc4bc034}
FullBody	Computed	{9c4be348-663a-4172-a38a-9714b2634c17}
Indentation	Computed	{26c4f53e-733a-4202-814b-377492b6c841}
IndentLevel	Computed	{68227570-72dd-4816-b6b6-4b81ff99a393}
IsRootPost	Computed	{bd2216c1-a2f3-48c0-b21c-dc297d0cc658}
LessLink	Computed	{076193bd-865b-4de7-9633-1f12069a6fff}
LimitedBody	Computed	{61b97279-cbc0-4aa9-a362-f1ff249c1706}
LinkDiscussionTitleNoMenu	Computed	{3ac9353f-613f-42bd-98e1-530e9fd1cbf6}
LinkDiscussionTitle	Computed	{46045bc4-283a-4826-b3dd-7a78d790b266}
MessageBody	Computed	{fbba993f-afee-4e00-b9be-36bc660dcd1}
MoreLink	Computed	{fb6c2494-1b14-49b0-a7ca-0506d6e85a62}
PersonImage	Computed	{adfe65ee-74bb-4771-bec5-d691d9a6a14e}
PersonViewMinimal	Computed	{b4ab471e-0262-462a-8b3f-c1dfc9e2d5fd}
QuotedTextWasExpanded	Computed	{e393d344-2e8c-425b-a8c3-89ac3144c9a2}
ReplyNoGif	Computed	{87cda0e2-fc57-4eec-a696-b0de2f61f361}
StatusBar	Computed	{f90bce56-87dc-4d73-bfcb-03fcfa670500}
Threading	Computed	Renders a view of an item of this thread, with indents for replies. Id: {58ca6516-51cd-41fb-a908-dd2a4aeea8bc}
ThreadingControls	Computed	{c55a4674-640b-4bae-8738-ce0439e6f6d4}
ToggleQuotedText	Computed	{e451420d-4e62-43e3-af83-010d36e353a2}

2.5.5 Survey

Survey is a base type for survey lists.

2.5.5.1 Data Fields

Field name	Type	Field ID or description
Completed	Computed	{35363960-d998-4aad-b7e8-058dfe2c669e}
HTML_x0020_File_x0020_Type	Computed	{4ef1b78f-fdba-48dc-b8ab-3fa06a0c9804}
Title	Text	Display name of the survey response. {e6f528fb-2e22-483d-9c80-f2536acdc6de}

2.5.5.2 HTML Rendering Fields

HTML rendering fields (2) provide views, in HTML, for data in a list item. HTML rendering fields (2) are specific to the user interface implementation, and instances of these fields (2) in a list item do not contain underlying data.

Field name	Type	Field ID or description
DisplayResponse	Computed	Displays a link to a response item. ID: {1443b460-28a8-4050-9994-c24971a765ec}
DisplayResponseNoMenu	Computed	Displays a link to a response item. ID: {f5fd696c-6384-4bb9-bc11-54fa101baf8f}

2.5.6 Issue

Issue serves as a base type for issue tracking lists.

2.5.6.1 Data Fields

Field name	Type	Field ID or description
_ModerationComments	Note	{34ad21eb-75bd-4544-8c73-0e08330291fe}
AssignedTo	User	{53101f38-dd2e-458c-b245-0c236cc13d1a}
Attachments	Attachments	{67df98f4-9dec-48ff-a553-29bece9c5bf4}
Category	Choice	{6df9bd52-550e-4a30-bc31-a4366832a87d}
Comment	Note	{6df9bd52-550e-4a30-bc31-a4366832a87f}
DueDate	DateTime	{cd21b4c2-6841-4f9e-a23a-738a65f99889}
GUID	Guid	{ae069f25-3ac2-4256-b9c3-15dbc15da0e0}
HTML_x0020_File_x0020_Type	Computed	{4ef1b78f-fdba-48dc-b8ab-3fa06a0c9804}
IsCurrent	Boolean	Indicates whether an issue is a historical copy of an item or a current version of an item. ID: {070bff9d-1307-455d-aebd-5b7164cb469e}
Priority	Choice	{a8eb573e-9e11-481a-a8c9-1104a54b2fbf}
RelatedIssue	Integer	Integer identifier of a related item.

Field name	Type	Field ID or description
		ID: {156af935-b442-4f69-a8b9-089100f2de78}
RelatedID	Guid	Identifier of a related item. Id: {801300c6-80c4-4758-8ce2-a38dec2e452f}
RelatedIssues	LookupMulti	{875fab27-6e95-463b-a4a6-82544f1027fb}
Status	Choice	{3f277a5c-c7ae-4bbe-9d44-0456fb548f94}
Title	Text	Display name of an item. {fa564e0f-0c70-4ab9-b863-0177e6ddd247}
V3Comments	Note	{6df9bd52-550e-4a30-bc31-a4366832a87e}

2.5.6.2 HTML Rendering Fields

HTML rendering fields (2) provide views, in HTML, for data in a list item. HTML rendering fields (2) are specific to the user interface implementation, and instances of these fields (2) in a list item do not contain underlying data.

Field name	Type	Field ID or description
Edit	Computed	{503f1caa-358e-4918-9094-4a2cdc4bc034}
IssueID	Computed	Rendition of the item identifier. ID: {de57307b-e69a-4cf9-b3a9-b6a728ecf773}
LinkIssueIDNoMenu	Computed	{03f89857-27c9-4b58-aaab-620647deda9b}
LinkTitle	Computed	{82642ec8-ef9b-478f-acf9-31f7d45fbc31}
LinkTitle2 <13>	Computed	{5f190d91-3dbc-4489-9878-3c092caf35b6}
LinkTitleNoMenu	Computed	{bc91a437-52e7-49e1-8c4e-4698904b2b6d}
LinkTitleVersionNoMenu	Computed	Renders a link to a version of an item. ID: {67f6307f-c161-4096-a5a7-b77016c08100}
RemoveRelatedID	Computed	{d8a2155a-aaf8-4d38-a14d-52bc83061d05}
SelectTitle	Computed	{b1f7969b-ea65-42e1-8b54-b588292635f2}

2.6 Content Types

The set of content types in the following sections represents the core set of content types that a protocol server implements.

2.6.1 Base Content Types

2.6.1.1 System

Id: 0x

The following table lists the fields (2).

Field name	Field ID
ContentType	{c042a256-787d-4a6f-8a8a-cf6ab767f12d}

This is the base content type of protocol server. This content type is abstract; a list item MUST NOT have this content type as its associated content type.

2.6.1.2 Item

Id: 0x01

The following table lists the fields (2).

Field name	Field ID
ContentType	{c042a256-787d-4a6f-8a8a-cf6ab767f12d}
Title	{fa564e0f-0c70-4ab9-b863-0177e6ddd247}

Specifies the base content type for a list item in a site (2). All list items in a site (2) have a content type that is, or derives from, this content type.

2.6.1.3 Document

Id: 0x0101

The following table lists the fields (2).

Field name	Field ID
ContentType	{c042a256-787d-4a6f-8a8a-cf6ab767f12d}
Created	{8c06beca-0777-48f7-91c7-6da68bc07b69}
Created_x0020_By	{4dd7e525-8d6b-4cb4-9d3e-44ee25f973eb}
FileLeafRef	{8553196d-ec8d-4564-9861-3dbe931050c8}
Modified	{28cf69c5-fa48-462a-b5cd-27b6f9d2bd5f}
Modified_x0020_By	{822c78e3-1ea9-4943-b449-57863ad33ca9}
SelectFilename	{5f47e085-2150-41dc-b661-442f3027f552}
Title	{fa564e0f-0c70-4ab9-b863-0177e6ddd247}

Specifies the base content type for a document in a site (2). All documents in a site have a content type that is, or derives from, this content type.

2.6.1.4 Folder

Id: 0x0120

The following table lists the fields (2).

Field name	Field ID
ContentType	{c042a256-787d-4a6f-8a8a-cf6ab767f12d}
FileLeafRef	{8553196d-ec8d-4564-9861-3dbe931050c8}
Title	{fa564e0f-0c70-4ab9-b863-0177e6ddd247}

Specifies the base content type for a folder in a site (2). All folders in a site (2) have a content type that is, or derives from, this content type.

2.7 List Template Types

The following table describes standard list template types used for storing data in a site (2). This does not include templates that can be additionally installed on a protocol server.

List template type	Template ID	Base type	Description
Custom List	100	0	A basic list that can be adapted for multiple purposes.
Document Library	101	1	Contains a list of documents and other files.
Survey	102	4	Fields (2) on a survey list represent questions that are asked of survey participants. Items in a list represent a set of responses to a survey.
Links	103	0	Contains a list of hyperlinks and their descriptions.
Announcements	104	0	Contains a set of simple announcements.
Contacts	105	0	Contains a list of contacts used for tracking people in a site (2).
Calendar	106	0	Contains a list of single and recurring events. An events list has special views for displaying events on a calendar.
Tasks	107	0	Contains a list of items that represent finished and pending work items.
Discussion Board	108	0	Contains discussions entries and their replies.
Picture Library	109	1	Contains a library adapted for storing and viewing digital pictures.
DataSources	110	1	Contains data connection description files.
Form Library	115	1	Contains XML documents. An XML form library can also contain templates for displaying and editing XML files through forms, as well as rules for specifying how XML data is converted to and from list items.
No Code Workflows	117	1	Contains additional workflow definitions that describe new processes that can be used in lists. These workflow definitions do not contain advanced code-based extensions.
Custom Workflow Process	118	0	Contains a list used to support custom workflow process actions.

List template type	Template ID	Base type	Description
Wiki Page Library	119	1	Contains a set of editable Web pages.
CustomGrid	120	0	Contains a set of list items with a grid-editing view.
No Code Public Workflows <14>	122	1	A gallery for storing workflow definitions that do not contain advanced code-based extensions.
Workflow History	140	0	Contains a set of history items for instances of workflows.
Project Tasks	150	0	Contains a list of tasks with specialized views of task data in the form of Gantt chart.
Public Workflows External List <15>	600	0	An external list for viewing the data of an external content type.
Issues Tracking	1100	5	Contains a list of items to track issues.

2.8 Common Data Structures and Enumerations

2.8.1 WorkflowEventType Enumeration

Contains an integer that corresponds to one of the values in the following table.

Value	Description
0	None. Workflow event is not of a particular type.
1	Workflow was started.
2	Workflow was finished.
3	Workflow was canceled.
4	Workflow was deleted.
5	Workflow task was created.
6	Workflow task was finished.
7	Workflow task was modified.
8	Workflow task was rolled back.
9	Workflow task was deleted.
10	Workflow has encountered an item.
11	Workflow has had a comment logged for it.

2.8.2 WorkflowStatus

An integer describing the status of the workflow. The following values are defined, but the field is vendor-extensible, and other values are allowed.

Value	Name	Description
0	WFSTAT_NOTSTARTED	The workflow has not yet started running.
1	WFSTAT_FAILEDTOSTART	The workflow failed to start.
2	WFSTAT_INPROGRESS	A front-end web server is processing the workflow.
3	WFSTAT_FAULTING	The workflow has encountered a faulting error.
4	WFSTAT_USERCANCEL	The workflow was canceled by a user.
5	WFSTAT_COMPLETED	The workflow has completely processed.
6	WFSTAT_FAILEDTOSTART_RETRY	The workflow failed to start. Processing can be attempted again.
7	WFSTAT_FAULTING_RETRY	The workflow has encountered a faulting error. Processing can be attempted again.

2.9 Expressions

A protocol server formula MUST be the same as those specified by [\[ISO/IEC29500-1:2011\]](#) section 18.17 with some deviation as specified by the following subsections.

2.9.1 Syntax

The syntax rules for formulas are the same as those specified by [\[ISO/IEC29500-1:2011\]](#) section 18.17.2, but the exact syntax structure MUST be as specified by the following **ABNF** [\[RFC5234\]](#).

```

formula = expression

expression = *space nospace-expression *space

space = " "

nospace-expression = "(" expression ")" / constant / (prefix-operator expression) /
(expression infix-operator expression) / data-reference / function-call

```

nospace-expression: Supports nesting expressions within other expressions. Expressions MUST NOT nest more than 64 levels deep.

<constant>: MUST be any constant defined by [\[ISO/IEC29500-1:2011\]](#) section 18.17.2.1 excluding array-constant.

```

infix-operator = "^" / "*" / "/" / "+" / "-" / "=" / "<>" / "<" / "<=" / ">" / ">="

prefix-operator = "-" / "+"

data-reference = field-name-no-spaces / (open-bracket field-name-with-spaces closed-bracket)

```

data-reference: Corresponds to the name of a field (2) in the current list (1).

```

field-name-no-spaces = 1*64name-character-no-space

```

name-character-no-space = character

name-character-no-space: MUST NOT be a space, open bracket ([), close bracket (]), or any character whose hexadecimal value is less than 0x20.

<character>: MUST be the production **Char** as specified by [\[W3C-XML\]](#) section 2.2.

open-bracket= "["

field-name-with-spaces = name-character-no-space [*62name-character name-character-no-space]

name-character = name-character-no-space / space

closed-bracket= "]"

function-call = predefined-function-call / defined-function-call

predefined-function-call = function-name "(" [argument-list] ")"

<function-name>: MUST be one of the functions listed in **Function Names** (section [2.9.2](#)).

argument-list = argument *253(comma argument)

comma= ","

argument = expression

defined-function-call = ("AND.DB" argument-list-params) / ("CONCATENATE.DB" argument-list-params) / ("DATETIME" datetime-params) / ("ISNULL" single-argument-params) / ("NOW.TIME()") / ("NULL()") / ("NZ" two-argument-params) / ("OR.DB" argument-list-params) / ("TRIMENDS" single-argument-params) / ("USDOLLAR" two-argument-params)

argument-list-params = "(" argument-list ")"

single-argument-params = "(" argument ")"

two-argument-params = "(" argument comma argument ")"

datetime-params = "(" argument 5*5(comma argument) ")"

2.9.2 Function Names

The set of predefined functions is divided into the functional categories in the following table. All references to subsections of 18.17.7 are in [\[ISO/IEC29500-1:2011\]](#).

Category	Formulas
Database	DAVERAGE section 18.17.7.77 DCOUNT section 18.17.7.81 DCOUNTA section 18.17.7.82 DGET section 18.17.7.90 DMAX section 18.17.7.92

Category	Formulas
	DMIN section 18.17.7.93 DPRODUCT section 18.17.7.97 DSTDEV section 18.17.7.98 DSTDEVP section 18.17.7.99 DSUM section 18.17.7.100 DVAR section 18.17.7.102 DVARP section 18.17.7.103
Date and time	DATE section 18.17.7.74 DATEDIF section 18.17.7.75 DATEVALUE section 18.17.7.76 DAY section 18.17.7.78 DAYS360 section 18.17.7.79 HOUR section 18.17.7.144 MINUTE section 18.17.7.214 MONTH section 18.17.7.220 NOW section 18.17.7.234 SECOND section 18.17.7.287 TIME section 18.17.7.323 TIMEVALUE section 18.17.7.324 TODAY section 18.17.7.326 WEEKDAY section 18.17.7.344 YEAR section 18.17.7.351
Financial	DB section 18.17.7.80 DDB section 18.17.7.83 FV section 18.17.7.129 IPMT section 18.17.7.172 IRR section 18.17.7.173 ISPMT section 18.17.7.184 MIRR section 18.17.7.216 NPER section 18.17.7.235 NPV section 18.17.7.236 PMT section 18.17.7.253 PPMT section 18.17.7.256 PV section 18.17.7.263 RATE section 18.17.7.270 SLN section 18.17.7.293 SYD section 18.17.7.314 VDB section 18.17.7.342
Information	CELL section 18.17.7.34 ERROR.TYPE section 18.17.7.110 ISBLANK section 18.17.7.174 ISERR section 18.17.7.175 ISERROR section 18.17.7.176 ISLOGICAL section 18.17.7.178

Category	Formulas
	ISNA section 18.17.7.179 ISNONTEXT section 18.17.7.180 ISNUMBER section 18.17.7.181 ISODD section 18.17.7.183 ISREF section 18.17.7.185 ISTEXT section 18.17.7.186 N section 18.17.7.223 NA section 18.17.7.224 TYPE section 18.17.7.334
Logical	AND section 18.17.7.9 FALSE section 18.17.7.117 IF section 18.17.7.147 NOT section 18.17.7.233 OR section 18.17.7.246 TRUE section 18.17.7.330
Lookup and reference	ADDRESS section 18.17.7.6 AREAS section 18.17.7.10 CHOOSE section 18.17.7.39 COLUMN section 18.17.7.42 COLUMNS section 18.17.7.43 HLOOKUP section 18.17.7.143 HYPERLINK section 18.17.7.145 INDEX section 18.17.7.166 INDIRECT section 18.17.7.167 LOOKUP section 18.17.7.202 MATCH section 18.17.7.204 OFFSET section 18.17.7.245 ROW section 18.17.7.281 ROWS section 18.17.7.282 TRANSPOSE section 18.17.7.327 VLOOKUP section 18.17.7.343
Math and Trig	ABS section 18.17.7.1 ACOS section 18.17.7.4 ACOSH section 18.17.7.5 ASIN section 18.17.7.12 ASINH section 18.17.7.13 ATAN section 18.17.7.14 ATAN2 section 18.17.7.15 ATANH section 18.17.7.16 CEILING section 18.17.7.33 COMBIN section 18.17.7.44 COS section 18.17.7.50 COSH section 18.17.7.51 DEGREES section 18.17.7.87

Category	Formulas
	EVEN section 18.17.7.111 EXP section 18.17.7.113 FACT section 18.17.7.115 FLOOR section 18.17.7.125 INT section 18.17.7.169 LN section 18.17.7.196 LOG section 18.17.7.197 LOG10 section 18.17.7.198 MDETERM section 18.17.7.207 MINVERSE section 18.17.7.215 MMULT section 18.17.7.217 MOD section 18.17.7.218 ODD section 18.17.7.240 PI section 18.17.7.252 POWER section 18.17.7.255 PRODUCT section 18.17.7.261 RADIANS section 18.17.7.266 RAND section 18.17.7.267 ROMAN section 18.17.7.277 ROUND section 18.17.7.278 ROUNDDOWN section 18.17.7.279 ROUNDUP section 18.17.7.280 SIGN section 18.17.7.289 SIN section 18.17.7.290 SINH section 18.17.7.291 SQRT section 18.17.7.296 SUBTOTAL section 18.17.7.305 SUM section 18.17.7.306 SUMIF section 18.17.7.307 SUMPRODUCT section 18.17.7.309 SUMSQ section 18.17.7.310 SUMX2MY2 section 18.17.7.311 SUMX2PY2 section 18.17.7.312 SUMXMY2 section 18.17.7.313 TAN section 18.17.7.316 TANH section 18.17.7.317 TRUNC section 18.17.7.332
Statistical	AVEDEV section 18.17.7.17 AVERAGE section 18.17.7.18 AVERAGEA section 18.17.7.19 BETADIST section 18.17.7.27 BETAINV section 18.17.7.28 BINOMDIST section 18.17.7.32 CHIDIST section 18.17.7.36 CHIINV section 18.17.7.37

Category	Formulas
	CHITEST section 18.17.7.38 CONFIDENCE section 18.17.7.47 CORREL section 18.17.7.49 COUNT section 18.17.7.52 COUNTA section 18.17.7.53 COUNTBLANK section 18.17.7.54 COUNTIF section 18.17.7.55 COVAR section 18.17.7.63 CRITBINOM section 18.17.7.64 DEVSQ section 18.17.7.89 EXPONDIST section 18.17.7.114 FDIST section 18.17.7.118 FINV section 18.17.7.121 FISHER section 18.17.7.122 FISHERINV section 18.17.7.123 FORECAST section 18.17.7.126 FREQUENCY section 18.17.7.127 FTEST section 18.17.7.128 GAMMADIST section 18.17.7.131 GAMMAINV section 18.17.7.132 GAMMALN section 18.17.7.133 GEOMEAN section 18.17.7.135 GROWTH section 18.17.7.138 HARMEAN section 18.17.7.139 HYPGEOMDIST section 18.17.7.146 INTERCEPT section 18.17.7.170 KURT section 18.17.7.188 LARGE section 18.17.7.189 LINEST section 18.17.7.195 LOGEST section 18.17.7.199 LOGINV section 18.17.7.200 LOGNORMDIST section 18.17.7.201 MAX section 18.17.7.205 MAXA section 18.17.7.206 MEDIAN section 18.17.7.209 MIN section 18.17.7.212 MINA section 18.17.7.213 MODE section 18.17.7.219 NEGBINOMDIST section 18.17.7.225 NORMDIST section 18.17.7.229 NORMINV section 18.17.7.230 NORMSDIST section 18.17.7.231 NORMSINV section 18.17.7.232 PEARSON section 18.17.7.247 PERCENTILE section 18.17.7.248

Category	Formulas
	PERCENTRANK section 18.17.7.249 PERMUT section 18.17.7.250 POISSON section 18.17.7.254 PROB section 18.17.7.260 QUARTILE section 18.17.7.264 RANK section 18.17.7.269 RSQ section 18.17.7.283 SKEW section 18.17.7.292 SLOPE section 18.17.7.294 SMALL section 18.17.7.295 STANDARDIZE section 18.17.7.298 STDEV section 18.17.7.299 STDEVA section 18.17.7.300 STDEVP section 18.17.7.301 STDEVPA section 18.17.7.302 STEYX section 18.17.7.303 TDIST section 18.17.7.321 TINV section 18.17.7.325 TREND section 18.17.7.328 TRIMMEAN section 18.17.7.330 TTEST section 18.17.7.333 VAR section 18.17.7.338 VARA section 18.17.7.339 VARP section 18.17.7.340 VARPA section 18.17.7.341 WEIBULL section 18.17.7.346 ZTEST section 18.17.7.356
Text and data	ASC section 18.17.7.11 CHAR section 18.17.7.35 CLEAN section 18.17.7.40 CODE section 18.17.7.41 CONCATENATE section 18.17.7.46 DOLLAR section 18.17.7.94 EXACT section 18.17.7.112 FIND section 18.17.7.119 FIXED section 18.17.7.124 LEFT section 18.17.7.191 LEN section 18.17.7.193 LOWER section 18.17.7.203 MID section 18.17.7.210 PROPER section 18.17.7.262 REPLACE section 18.17.7.272 REPT section 18.17.7.274 RIGHT section 18.17.7.275 SEARCH section 18.17.7.285

Category	Formulas
	SUBSTITUTE section 18.17.7.304 T section 18.17.7.315 TEXT section 18.17.7.322 TRIM section 18.17.7.329 UPPER section 18.17.7.335 VALUE section 18.17.7.337

3 Structure Examples

The following state diagram represents an example structure and scenario of a protocol server farm and its constituent sites (2). This example represents the structure of a basic intranet set of sites (2).

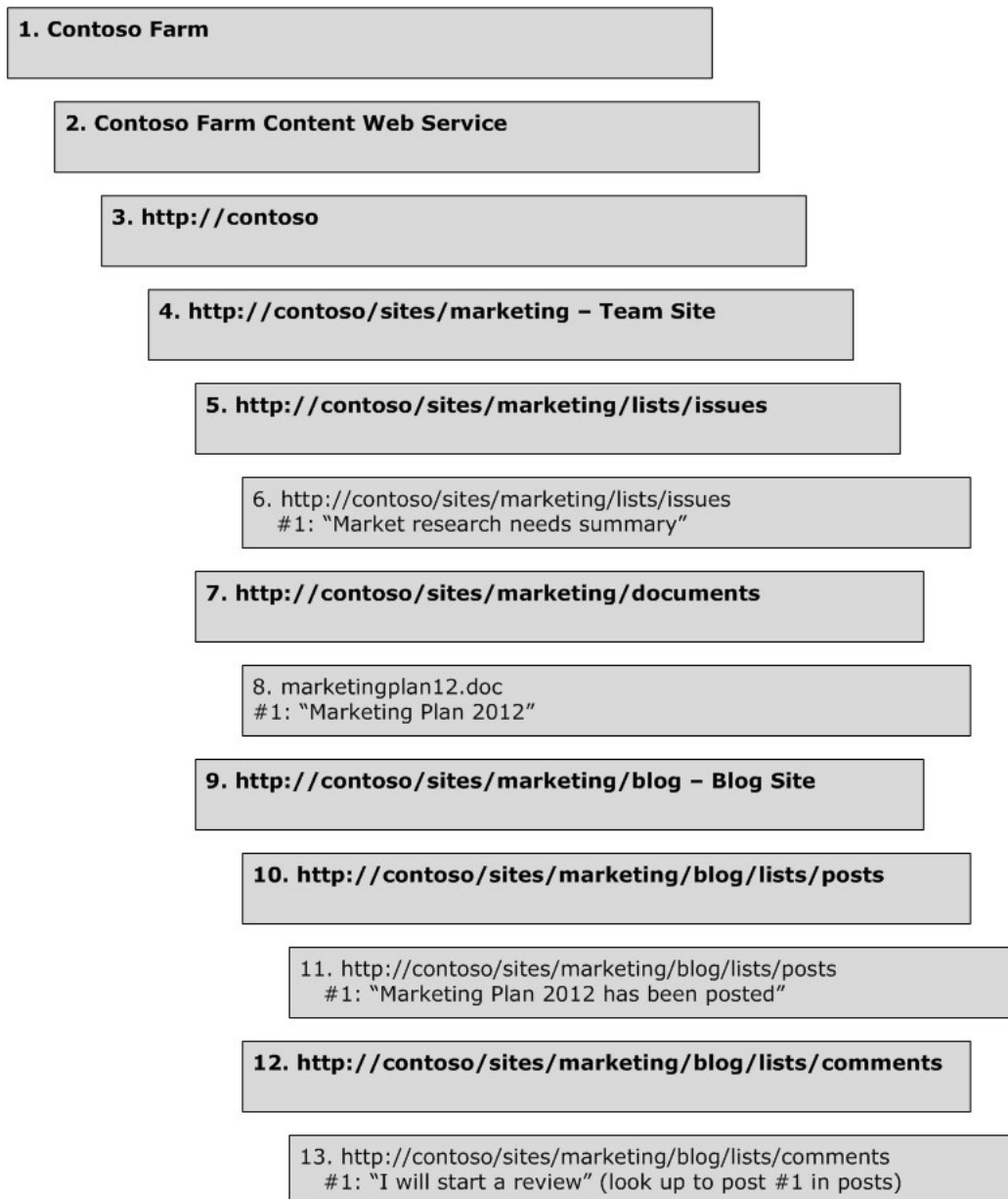

Figure 3: Example structure of administration and content objects

The following objects are used in the example:

1. A farm administration object that describes the Contoso farm and its administration, as well as settings that apply to all objects in the farm.
2. A service that renders Web site content for the Contoso farm.
3. A Web application with a root server base URL of `http://contoso/`.
4. The `/marketing` segment represents a site collection that stores content for a marketing team. The `/marketing` site has a wildcard managed path (`/sites/`) that supports multiple child site collections. `/marketing` not only represents the entire site collection (sites and subsites under that path segment in the URL hierarchy), but also a root team site at `/marketing`, as well as a root folder at `/marketing`. The root team site (2) is a site (2) based on the Team Site site definition.
5. The `/issues` segment represents a list of issues. The base type of this list is 5, and the type of the list template is 1100. The `/issues` segment has a parent site (`/marketing`), but it also has a parent folder (`/lists`). In this example, this is the `/lists` simple folder that groups multiple lists.
6. An item in the issue list. The issue has an identifier of #1 and contains data for various fields (2), such as the issue title.
7. The `/documents` segment represents a document library for containing documents. The base type of this library is 1, and the type of the list template is 101. The parent site of this library is `/marketing`, and the parent folder of this library is `/marketing` as well.
8. The `marketingplan08.doc` segment represents a document contained in the document library. A file is located at `http://contoso/sites/marketing/documents/marketingplan08.doc`. A list item with an identifier of #1 corresponding to `marketingplan08.doc` is also stored, which contains additional properties of the document, such as the document title.
9. The `/blog` segment represents a subsite in the `/marketing` site collection, as well as a folder called `/blog`. The parent site of `/blog` is `/marketing`. The `/blog` site (2) is based on a custom blog site definition.
10. The `/posts` segment represents a list of blog posts. The base type of this list is zero, and the type of the list template is 301. The list template is defined in the blog site definition.
11. A post list item with an item identifier of 1 is in the `/posts` list. This list item contains content for fields (2) of the post list, including the body of post content.
12. The `/comments` segment represents a list of comments for blog posts. The base type of this list is zero, and the type of the list template is 302. The list template is defined in the blog site definition.
13. A comment list item with an item identifier of 1 is in the `/comments` list. This list item contains content for various fields (2) of the comment list, including the body of comment content. This list item also has a lookup field defined, and item #1 has a lookup field to item #1 in the Posts list.

4 Security

4.1 Security Considerations for Implementers

None.

4.2 Index of Security Fields

None.

5 Appendix A: Product Behavior

The information in this specification is applicable to the following Microsoft products or supplemental software. References to product versions include released service packs:

- Microsoft SharePoint Foundation 2010
- Windows SharePoint Services 3.0
- Microsoft SharePoint Foundation 2013

Exceptions, if any, are noted below. If a service pack or Quick Fix Engineering (QFE) number appears with the product version, behavior changed in that service pack or QFE. The new behavior also applies to subsequent service packs of the product unless otherwise specified. If a product edition appears with the product version, behavior is different in that product edition.

Unless otherwise specified, any statement of optional behavior in this specification that is prescribed using the terms SHOULD or SHOULD NOT implies product behavior in accordance with the SHOULD or SHOULD NOT prescription. Unless otherwise specified, the term MAY implies that the product does not follow the prescription.

[<1> Section 2.1.2.16.1:](#) In Windows SharePoint Services 3.0 and SharePoint Foundation 2010, these nodes are not hidden when rendered using a site map provider.

[<2> Section 2.1.2.16.2:](#) In Windows SharePoint Services 3.0 and SharePoint Foundation 2010, the following navigation node element identifiers have a special meaning:

- 1000 represents the navigation node pointing to the home page of the site (2).
- 1002 represents a navigation node that is the parent of all navigation nodes that are rendered on the top of every page. This navigation node is of type zero with the **LinkBar** property set to 1.
- 1025 represents a navigation node that is the parent of a set of navigation nodes that link to the most commonly used lists, document libraries, and other pages. This navigation node is of type zero with the **LinkBar** property set to 1.

[<3> Section 2.5:](#) In Windows SharePoint Services 3.0, the discussion board base type is obsolete. New discussion boards use the generic list base type.

[<4> Section 2.5.1.1:](#) Windows SharePoint Services 3.0 does not have this field.

[<5> Section 2.5.1.1:](#) In Windows SharePoint Services 3.0, only the Discussion Board list has this field, and other kinds of lists do not have this field.

[<6> Section 2.5.1.1:](#) Windows SharePoint Services 3.0 does not have this field.

[<7> Section 2.5.1.1:](#) Windows SharePoint Services 3.0 does not have this field.

[<8> Section 2.5.1.2:](#) Windows SharePoint Services 3.0 does not have this field.

[<9> Section 2.5.1.2:](#) Windows SharePoint Services 3.0 does not have this field.

[<10> Section 2.5.2.2:](#) Windows SharePoint Services 3.0 does not contain this field.

[<11> Section 2.5.3.1:](#) Windows SharePoint Services 3.0 does not contain this field.

[<12> Section 2.5.4:](#) In Windows SharePoint Services 3.0, the discussion board base type is obsolete. New discussion boards use the generic list base type.

[<13> Section 2.5.6.2:](#) Windows SharePoint Services 3.0 does not contain this field.

[<14> Section 2.7:](#) Windows SharePoint Services 3.0 does not support this template type.

[<15> Section 2.7:](#) Windows SharePoint Services 3.0 does not support this template type.

6 Change Tracking

No table of changes is available. The document is either new or has had no changes since its last release.

7 Index

A

- [Abstract data structures](#) 11
- [Administration and configuration](#) 11
- [Administration object](#) 12
- [Administration Web service object](#) 12
- [Applicability](#) 9
- Authentication
 - [group](#) 24
 - [permission](#) 24
 - [principal](#) 24
 - read my own
 - [write my own](#) 25
 - [role definition](#) 25
 - [scope](#) 24
 - [securable object](#) 24
- [Authentication and security](#) 23
- [Authentication system](#) 23

B

- Base data fields ([section 2.4.2](#) 28, [section 2.4.4](#) 33)
- [Base field types](#) 26
- Base rendering fields ([section 2.4.3](#) 32, [section 2.4.4](#) 33, [section 2.4.5](#) 33)
- [Base types - list](#) 34

C

- [Change tracking](#) 58
- [Common data types and fields](#) 11
- [Common list item fields](#) 34
- Configuration
 - [administration object](#) 12
 - [administration Web service object](#) 12
 - [authentication and security](#) 23
 - [authentication system](#) 23
 - [content](#) 13
 - [content type](#) 16
 - [content Web service object](#) 12
 - [document](#) 18
 - [farm](#) 11
 - [feature](#) 23
 - [field](#) 17
 - [file](#) 14
 - [folder](#) 14
 - [generic list items](#) 19
 - [HTML user interface infrastructure](#) 20
 - [list](#) 15
 - [list definition](#) 22
 - [list item](#) 17
 - [managed path](#) 14
 - [metadict](#) 20
 - [namespace](#) 13
 - [Navigation structure](#) 21
 - [service](#) 12
 - [site](#) 15
 - [site collection](#) 15
 - [site definition](#) 22

- [Web application](#) 12
- [workflow](#) 20
- [Content](#) 13
- [Content type](#) 16
- [Content types](#) 41
 - [Document](#) 42
 - [folder](#) 42
 - [Item](#) 42
 - [System](#) 41
- [Content Web service object](#) 12

D

- Data fields
 - base data fields ([section 2.4.2](#) 28, [section 2.4.4](#) 33)
 - [Data fields - discussion board](#) 38
 - [Data fields - document](#) 37
 - [Data fields - issue](#) 40
 - [Data fields - list](#) 36
 - [Data fields - list item](#) 34
 - [Data fields - survey](#) 40
- Data structures
 - [abstract](#) 11
- [Data types and fields - common](#) 11
- Details
 - [common data types and fields](#) 11
 - [Discussion board](#) 38
- Document ([section 2.1.2.11](#) 18, [section 2.5.3](#) 37)
- [Document content type](#) 42
- [Document lookup](#) 28

E

- Enumerations
 - [WorkflowEventType](#) 44
- [Examples](#) 53
 - [overview](#) 53
- Expressions
 - [function names](#) 46
 - [overview](#) 45
 - [syntax](#) 45
- [Extended field types](#) 28

F

- [Farm](#) 11
- [Feature](#) 23
- [Field](#) 17
- Field types
 - [base field types](#) 26
 - [extended field types](#) 28
- Fields
 - base data fields ([section 2.4.2](#) 28, [section 2.4.4](#) 33)
 - base rendering fields ([section 2.4.3](#) 32, [section 2.4.4](#) 33, [section 2.4.5](#) 33)
 - [discussion board](#) 38
 - [discussion board data](#) 38

- [discussion board HTML rendering](#) 39
- [document](#) 37
- [document data](#) 37
- [document HTML rendering](#) 38
- [document lookup](#) 28
- [generic list](#) 36
- [issue](#) 40
- [issue data](#) 40
- [issue HTML rendering](#) 41
- [list data](#) 36
- [list HTML rendering fields](#) 36
- [list item](#) 34
- [list item data](#) 34
- [list item HTML rendering](#) 35
- [survey](#) 39
- survey data ([section 2.4.6](#) 34, [section 2.5.5.1](#) 40)
- [survey HTML rendering](#) 40
- [XML document rendering fields](#) 33
- [Fields - security index](#) 55
- [Fields - vendor-extensible](#) 10
- [File](#) 14
- [File system object constraints](#) 25
- [Folder](#) 14
- [Folder content type](#) 42
- [Function names](#) 46

G

- [Generic list](#) 36
- [Generic list items](#) 19
- [Glossary](#) 7
- [Group](#) 24

H

- [HTML rendering fields - discussion board](#) 39
- [HTML rendering fields - document](#) 38
- [HTML rendering fields - issue](#) 41
- [HTML rendering fields - list](#) 36
- [HTML rendering fields - list item](#) 35
- [HTML rendering fields - survey](#) 40
- [HTML user interface infrastructure](#) 20

I

- [Implementer - security considerations](#) 55
- [Index of security fields](#) 55
- [Informative references](#) 9
- [Introduction](#) 7
- [Issue](#) 40
- [Item content type](#) 42

L

- [List](#) 15
- [List base types](#) 34
- [List definition](#) 22
- [List item](#) 17
- [List item - fields](#) 34
- [List template types](#) 23
- [Localization](#) 9

M

- [Managed path](#) 14
- [Metadict](#) 20

N

- [Namespace](#) 13
- [Navigation structure](#) 21
- [Normative references](#) 8

O

- Object-level constraints
 - [file system object constraints](#) 25
 - [site constraints](#) 26
- [Overview \(synopsis\)](#) 9

P

- [Permission](#) 24
- [Principal](#) 24
- [Product behavior](#) 56
- Provisioning data
 - [feature](#) 23
 - [list definition](#) 22
 - [site definition](#) 22

R

- Read my own
 - [write my own](#) 25
- [References](#) 8
 - [informative](#) 9
 - [normative](#) 8
- [Relationship to protocols and other structures](#) 9
- Rendering
 - base rendering fields ([section 2.4.3](#) 32, [section 2.4.4](#) 33, [section 2.4.5](#) 33)
- [Role definition](#) 25

S

- [Scope](#) 24
- [Securable object](#) 24
- Security
 - [authentication system](#) 23
 - [field index](#) 55
 - [group](#) 24
 - [implementer considerations](#) 55
 - [permission](#) 24
 - [principal](#) 24
 - read my own
 - [write my own](#) 25
 - [role definition](#) 25
 - [scope](#) 24
 - [securable object](#) 24
- [Service](#) 12
- [Site](#) 15
- [Site collection](#) 15
- [Site constraints](#) 26
- [Site definition](#) 22

Structures

[feature](#) 23

[list definition](#) 22

[Navigation](#) 21

[overview](#) 11

[site definition](#) 22

[Survey](#) 39

[Survey data fields](#) 34

[Syntax](#) 45

[System content type](#) 41

T

Template types

[list](#) 43

[Tracking changes](#) 58

V

[Vendor-extensible fields](#) 10

[Versioning](#) 9

W

[Web application](#) 12

[Workflow](#) 20

[WorkflowEventType enumeration](#) 44

X

[XML document rendering fields](#) 33