

[MS-OCPSTN]: Session Initiation Protocol (SIP) for PSTN Calls Extensions

Intellectual Property Rights Notice for Open Specifications Documentation

- **Technical Documentation.** Microsoft publishes Open Specifications documentation for protocols, file formats, languages, standards as well as overviews of the interaction among each of these technologies.
- **Copyrights.** This documentation is covered by Microsoft copyrights. Regardless of any other terms that are contained in the terms of use for the Microsoft website that hosts this documentation, you may make copies of it in order to develop implementations of the technologies described in the Open Specifications and may distribute portions of it in your implementations using these technologies or your documentation as necessary to properly document the implementation. You may also distribute in your implementation, with or without modification, any schema, IDL's, or code samples that are included in the documentation. This permission also applies to any documents that are referenced in the Open Specifications.
- **No Trade Secrets.** Microsoft does not claim any trade secret rights in this documentation.
- **Patents.** Microsoft has patents that may cover your implementations of the technologies described in the Open Specifications. Neither this notice nor Microsoft's delivery of the documentation grants any licenses under those or any other Microsoft patents. However, a given Open Specification may be covered by Microsoft [Open Specification Promise](#) or the [Community Promise](#). If you would prefer a written license, or if the technologies described in the Open Specifications are not covered by the Open Specifications Promise or Community Promise, as applicable, patent licenses are available by contacting iplg@microsoft.com.
- **Trademarks.** The names of companies and products contained in this documentation may be covered by trademarks or similar intellectual property rights. This notice does not grant any licenses under those rights. For a list of Microsoft trademarks, visit www.microsoft.com/trademarks.
- **Fictitious Names.** The example companies, organizations, products, domain names, email addresses, logos, people, places, and events depicted in this documentation are fictitious. No association with any real company, organization, product, domain name, email address, logo, person, place, or event is intended or should be inferred.

Reservation of Rights. All other rights are reserved, and this notice does not grant any rights other than specifically described above, whether by implication, estoppel, or otherwise.

Tools. The Open Specifications do not require the use of Microsoft programming tools or programming environments in order for you to develop an implementation. If you have access to Microsoft programming tools and environments you are free to take advantage of them. Certain Open Specifications are intended for use in conjunction with publicly available standard specifications and network programming art, and assumes that the reader either is familiar with the aforementioned material or has immediate access to it.

Revision Summary

Date	Revision History	Revision Class	Comments
04/04/2008	0.1		Initial version
04/25/2008	0.2		Updated based on feedback
06/27/2008	1.0		Updated and revised the technical content.
08/15/2008	1.01		Revised and edited the technical content.
09/12/2008	1.02		Revised and edited the technical content.
12/12/2008	2.0		Updated and revised the technical content.
02/13/2009	2.01		Revised and edited the technical content.
03/13/2009	2.02		Revised and edited the technical content.
07/13/2009	2.03	Major	Revised and edited the technical content
08/28/2009	2.04	Editorial	Revised and edited the technical content
11/06/2009	2.05	Editorial	Revised and edited the technical content
02/19/2010	2.06	Editorial	Revised and edited the technical content
03/31/2010	2.07	Major	Updated and revised the technical content
04/30/2010	2.08	Editorial	Revised and edited the technical content
06/07/2010	2.09	Editorial	Revised and edited the technical content
06/29/2010	2.10	Editorial	Changed language and formatting in the technical content.
07/23/2010	2.10	No change	No changes to the meaning, language, or formatting of the technical content.
09/27/2010	3.0	Major	Significantly changed the technical content.
11/15/2010	3.0	No change	No changes to the meaning, language, or formatting of the technical content.
12/17/2010	3.0	No change	No changes to the meaning, language, or formatting of the technical content.
03/18/2011	3.0	No change	No changes to the meaning, language, or formatting of the technical content.
06/10/2011	3.0	No change	No changes to the meaning, language, or formatting of the technical content.
01/20/2012	4.0	Major	Significantly changed the technical content.
04/11/2012	4.0	No change	No changes to the meaning, language, or formatting of

Date	Revision History	Revision Class	Comments
			the technical content.
07/16/2012	4.0	No change	No changes to the meaning, language, or formatting of the technical content.
10/08/2012	4.0.1	Editorial	Changed language and formatting in the technical content.
02/11/2013	4.0.1	No change	No changes to the meaning, language, or formatting of the technical content.
07/30/2013	4.0.1	No change	No changes to the meaning, language, or formatting of the technical content.
11/18/2013	4.0.1	No change	No changes to the meaning, language, or formatting of the technical content.
02/10/2014	4.0.1	No change	No changes to the meaning, language, or formatting of the technical content.

Table of Contents

1 Introduction	8
1.1 Glossary	8
1.2 References	9
1.2.1 Normative References	9
1.2.2 Informative References	9
1.3 Overview	10
1.4 Relationship to Other Protocols	11
1.5 Prerequisites/Preconditions	12
1.6 Applicability Statement	12
1.7 Versioning and Capability Negotiation	12
1.8 Vendor-Extensible Fields	12
1.9 Standards Assignments	12
2 Messages	13
2.1 Transport	13
2.2 Message Syntax	13
2.2.1 isGateway	13
2.2.2 phone-context	13
2.2.3 ms-call-source	14
2.2.4 ms-early-media	14
2.2.5 Anonymous Phone URI	14
2.2.6 ms-bypass	14
2.2.7 ms-accepted-content-id	14
2.2.8 ms-trunking-peer	15
2.2.9 ms-mediation-generated	15
3 Protocol Details	16
3.1 isGateway Details	16
3.1.1 Abstract Data Model	16
3.1.2 Timers	16
3.1.3 Initialization	16
3.1.4 Higher-Layer Triggered Events	16
3.1.5 Message Processing Events and Sequencing Rules	16
3.1.6 Timer Events	16
3.1.7 Other Local Events	16
3.2 phone-context Details	16
3.2.1 Abstract Data Model	17
3.2.2 Timers	17
3.2.3 Initialization	17
3.2.4 Higher-Layer Triggered Events	18
3.2.5 Message Processing Events and Sequencing Rules	18
3.2.6 Timer Events	18
3.2.7 Other Local Events	18
3.3 ms-call-source Details	18
3.3.1 Abstract Data Model	18
3.3.2 Timers	18
3.3.3 Initialization	19
3.3.4 Higher-Layer Triggered Events	19
3.3.5 Message Processing Events and Sequencing Rules	19
3.3.6 Timer Events	19

3.3.7	Other Local Events	19
3.4	ms-early-media Details	19
3.4.1	Abstract Data Model	19
3.4.2	Timers	19
3.4.3	Initialization	19
3.4.4	Higher-Layer Triggered Events.....	20
3.4.5	Message Processing Events and Sequencing Rules.....	20
3.4.6	Timer Events	20
3.4.7	Other Local Events	20
3.5	Anonymous Phone URI Details.....	20
3.5.1	Abstract Data Model	20
3.5.2	Timers	20
3.5.3	Initialization	20
3.5.4	Higher-Layer Triggered Events.....	20
3.5.5	Message Processing Events and Sequencing Rules.....	20
3.5.6	Timer Events	20
3.5.7	Other Local Events	20
3.6	ms-bypass Details	21
3.6.1	Abstract Data Model	21
3.6.2	Timers	21
3.6.3	Initialization	21
3.6.4	Higher-Layer Triggered Events.....	21
3.6.5	Message Processing Events and Sequencing Rules.....	21
3.6.6	Timer Events	21
3.6.7	Other Local Events	21
3.7	ms-accepted-content-id Details	21
3.7.1	Abstract Data Model	22
3.7.2	Timers	22
3.7.3	Initialization	22
3.7.4	Higher-Layer Triggered Events.....	22
3.7.5	Message Processing Events and Sequencing Rules.....	22
3.7.6	Timer Events	22
3.7.7	Other Local Events	22
3.8	ms-trunking-peer Details.....	22
3.8.1	Abstract Data Model	22
3.8.2	Timers	22
3.8.3	Initialization	22
3.8.4	Higher-Layer Triggered Events.....	22
3.8.5	Message Processing Events and Sequencing Rules.....	22
3.8.6	Timer Events	23
3.8.7	Other Local Events	23
3.9	ms-mediation-generated Details.....	23
3.9.1	Abstract Data Model	23
3.9.2	Timers	23
3.9.3	Initialization	23
3.9.4	Higher-Layer Triggered Events.....	23
3.9.5	Message Processing Events and Sequencing Rules.....	23
3.9.6	Timer Events	23
3.9.7	Other Local Events	23
4	Protocol Examples.....	24
4.1	isGateway SIP Contact Header Parameter.....	24
4.1.1	Inbound Call.....	24

4.1.1.1	Step 3: INVITE Message Is Received by the UAC	24
4.1.1.2	Step 7: 200 Message Is Sent from the UAC.....	25
4.1.2	Outbound Call.....	26
4.1.2.1	Step 1: INVITE Message Is Sent from the UAC	26
4.1.2.2	Step 12: 200 Message Is Received by the UAC.....	27
4.2	phone-context SIP URI Parameter.....	28
4.2.1	Inbound Call	28
4.2.1.1	Step 3: INVITE Message Is Received by the UAC	28
4.2.1.2	Step 7: 200 Message Is Sent from the UAC.....	29
4.2.2	Outbound Call.....	30
4.2.2.1	Step 1: INVITE Message Is Sent from the UAC	30
4.2.2.2	Step 12: 200 Message Is Received by the UAC.....	31
4.3	ms-call-source SIP Header	32
4.3.1	Inbound Call	32
4.3.1.1	Step 2: INVITE Message Is Received by the UAC	32
4.3.1.2	Step 8: INVITE Message Is Received by the UAC	33
4.3.1.3	Step 9: 605 Message Is Sent from the UAC.....	33
4.3.1.4	Step 12: 200 Message Is Sent from the UAC	34
4.3.2	Outbound Call	34
4.4	ms-early-media SIP Supported Header Option Tag.....	34
4.4.1	Inbound Call	34
4.4.2	Outbound Call	35
4.4.2.1	Step 1: INVITE Is Sent from the UAC.....	35
4.4.2.2	Step 7: 183 Message Is Received by the UAC.....	36
4.4.2.3	Step 12: 200 Message Is Received by the UAC.....	37
4.5	ms-bypass SIP Supported Header Option Tag.....	39
4.5.1	Inbound Call	39
4.5.1.1	Step 6: INVITE Message Is Received by the Protocol Client.....	39
4.5.1.2	Step 17: 200 Message Is Sent by the Protocol Client.....	41
4.5.2	Outbound Call	42
4.5.2.1	Step 1: INVITE Message Is Sent by the Protocol Client	42
4.5.2.2	Step 13: 200 OK Message Is Received by the Protocol Client	45
4.6	ms-accepted-content-id SIP Header	46
4.6.1	Inbound Call	46
4.6.1.1	Step 6: INVITE Message Is Received by the Protocol Client.....	47
4.6.1.2	Step 17: 200 Message Is Sent by the Protocol Client.....	48
4.6.2	Outbound Call.....	49
4.6.2.1	Step 1: INVITE Message Is Sent by the Protocol Client.....	50
4.6.2.2	Step 13: 200 Message Is Received by the Protocol Client.....	52
4.7	ms-trunking-peer SIP Header.....	53
4.7.1	Inbound Call	53
4.7.1.1	Step 6: INVITE Message Is Received by the Protocol Client.....	53
4.7.2	Outbound Call.....	55
4.7.2.1	Step 13: 200 Message Is Received by the Protocol Client.....	55
4.8	ms-mediation-generated SIP Header	56
4.8.1	Outbound Call	57
4.8.1.1	Step 5: 183 Message Is Received by the Protocol Client	57
4.8.1.2	Step 9: 180 Message Is Received by the Protocol Client	58
5	Security.....	59
5.1	Security Considerations for Implementers.....	59
5.2	Index of Security Parameters	59

6	Appendix A: Product Behavior	60
7	Change Tracking.....	62
8	Index	63

1 Introduction

The **Session Initiation Protocol (SIP)** for public switched telephone network (PSTN) Calls Extensions protocol consists of proprietary extensions applicable for interfacing a protocol client with other traditional telephony networks, such as the public switched telephone network (PSTN) and an enterprise private branch exchange (PBX) or IP-PBX.

Sections 1.8, 2, and 3 of this specification are normative and can contain the terms MAY, SHOULD, MUST, MUST NOT, and SHOULD NOT as defined in RFC 2119. Sections 1.5 and 1.9 are also normative but cannot contain those terms. All other sections and examples in this specification are informative.

1.1 Glossary

The following terms are defined in [\[MS-GLOS\]](#):

Augmented Backus-Naur Form (ABNF)
domain
fully qualified domain name (FQDN)

The following terms are defined in [\[MS-OFCGLOS\]](#):

200 OK
answer
call
dial plan
dialog
INVITE
Multipurpose Internet Mail Extensions (MIME)
offer
private branch exchange (PBX)
proxy
public switched telephone network (PSTN)
SDP answer
SDP offer
Session Description Protocol (SDP)
Session Initiation Protocol (SIP)
SIP message
SIP transaction
Uniform Resource Identifier (URI)
user agent client (UAC)
user agent server (UAS)

The following terms are specific to this document:

dial string: The numbers, symbols, and pauses that users enter to place a phone call. It is consumed by one or more network entities and understood in the context of the configuration of those entities. It is used to generate an address-of-record or identifier to route a call.

E.164: An international public telecommunication numbering plan that is used in the public switched telephone network (PSTN) and some data networks. It defines the format of telephone numbers. E.164 numbers can have a maximum of 15 digits and typically are written with a plus sign (+) prefix.

early media: Media, such as audio and video, that is exchanged before a specific session is accepted by the called user. During a dialog, early media occurs when the initial INVITE is sent, until the user agent server (UAS) generates a final response.

gateway: A network edge device that bridges Microsoft Office Communications Server protocols with legacy telephony networks protocols.

IP-PBX: A PBX that supports Voice over IP (VoIP).

P-Asserted-Identity (PAI): A Session Initiation Protocol (SIP) header field, as described in [RFC3325], that is used by trusted entities to carry the identity of the user who is sending an SIP message as it was verified by authentication (2).

MAY, SHOULD, MUST, SHOULD NOT, MUST NOT: These terms (in all caps) are used as described in [RFC2119]. All statements of optional behavior use either MAY, SHOULD, or SHOULD NOT.

1.2 References

References to Microsoft Open Specifications documentation do not include a publishing year because links are to the latest version of the documents, which are updated frequently. References to other documents include a publishing year when one is available.

1.2.1 Normative References

We conduct frequent surveys of the normative references to assure their continued availability. If you have any issue with finding a normative reference, please contact dochelp@microsoft.com. We will assist you in finding the relevant information.

[MS-SDPEXT] Microsoft Corporation, "[Session Description Protocol \(SDP\) Version 2.0 Extensions](#)".

[RFC2045] Freed, N., and Borenstein, N., "Multipurpose Internet Mail Extensions (MIME) Part One: Format of Internet Message Bodies", RFC 2045, November 1996, <http://ietf.org/rfc/rfc2045.txt>

[RFC2111] Levinson, E., "Content-ID and Message-ID Uniform Resource Locators", RFC 2111, March 1997, <http://www.rfc-editor.org/rfc/rfc2111.txt>

[RFC2119] Bradner, S., "Key words for use in RFCs to Indicate Requirement Levels", BCP 14, RFC 2119, March 1997, <http://www.rfc-editor.org/rfc/rfc2119.txt>

[RFC3261] Rosenberg, J., Schulzrinne, H., Camarillo, G., Johnston, A., Peterson, J., Sparks, R., Handley, M., and Schooler, E., "SIP: Session Initiation Protocol", RFC 3261, June 2002, <http://www.ietf.org/rfc/rfc3261.txt>

[RFC3966] Schulzrinne, H., "The tel URI for Telephone Numbers", RFC 3966, December 2004, <http://www.rfc-editor.org/rfc/rfc3966.txt>

1.2.2 Informative References

[MS-GLOS] Microsoft Corporation, "[Windows Protocols Master Glossary](#)".

[MS-OFGLGLOS] Microsoft Corporation, "[Microsoft Office Master Glossary](#)".

[MS-SIPAE] Microsoft Corporation, "[Session Initiation Protocol \(SIP\) Authentication Extensions](#)".

[MS-SIPRE] Microsoft Corporation, "[Session Initiation Protocol \(SIP\) Routing Extensions](#)".

- [MS-SIPREGE] Microsoft Corporation, "[Session Initiation Protocol \(SIP\) Registration Extensions](#)".
- [RFC3262] Rosenberg, J., and Schulzrinne, H., "Reliability of Provisional Responses in the Session Initiation Protocol (SIP)", RFC 3262, June 2002, <http://www.ietf.org/rfc/rfc3262.txt>
- [RFC3263] Rosenberg, J., and Schulzrinne, H., "Session Initiation Protocol (SIP): Locating SIP Servers", RFC 3263, June 2002, <http://www.ietf.org/rfc/rfc3263.txt>
- [RFC3264] Rosenberg, J., and Schulzrinne, H., "An Offer/Answer Model with the Session Description Protocol (SDP)", RFC 3264, June 2002, <http://www.rfc-editor.org/rfc/rfc3264.txt>
- [RFC3325] Jennings, C., Peterson, J., and Watson, M., "Private Extensions to the Session Initiation Protocol (SIP) for Asserted Identity within Trusted Networks", RFC 3325, November 2002, <http://www.rfc-editor.org/rfc/rfc3325.txt>
- [RFC3515] Sparks, R., "The Session Initiation Protocol (SIP) Refer Method", RFC 3515, April 2003, <http://www.ietf.org/rfc/rfc3515.txt>
- [RFC3891] Mahy, R., Biggs, B., and Dean, R., "The Session Initiation Protocol (SIP) "Replaces" Header", RFC 3891, September 2004, <http://www.rfc-editor.org/rfc/rfc3891.txt>
- [RFC3892] Sparks, R., "The Session Initiation Protocol (SIP) Referred-By Mechanism", RFC 3892, September 2004, <http://www.rfc-editor.org/rfc/rfc3892.txt>
- [RFC5234] Crocker, D., Ed., and Overell, P., "Augmented BNF for Syntax Specifications: ABNF", STD 68, RFC 5234, January 2008, <http://www.rfc-editor.org/rfc/rfc5234.txt>

1.3 Overview

This protocol adds extensions to the Session Initiation Protocol (SIP), for interfacing a protocol client with other traditional telephony networks, such as a **public switched telephone network (PSTN)** and an enterprise **private branch exchange (PBX)** or **IP-PBX**.

The logical entities that are affected by these extensions are protocol client, server (**proxy**), and **gateway** entities. The protocol client and the gateway can function as a **user agent client (UAC)** or **user agent server (UAS)**, depending on their role in the **SIP transaction**, as illustrated in the following diagram.

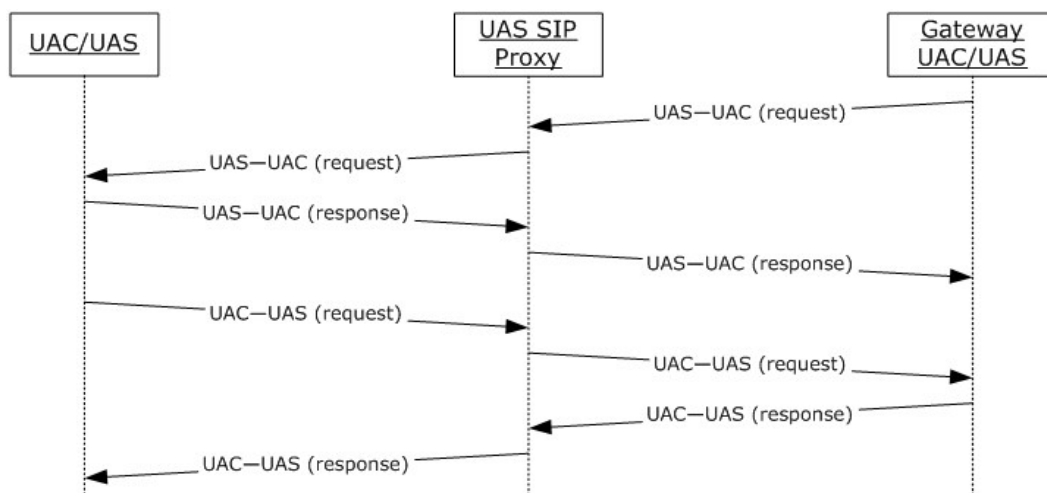

Figure 1: SIP transaction

The extensions do the following:

- Enable a SIP user agent (SIP UA) to be aware that a remote SIP UA in a SIP **dialog** is a gateway, as described in section [2.2.1](#) and section [3.1](#). This information can be rendered to the user interface (UI) to provide a better user experience (UX).
- Enable a SIP **URI** to hold an address of a **dial string** that is given by a user, as described in section [2.2.2](#) and section [3.2](#).
- Enable a SIP UAS to detect a redundant **call** that is triggered as a result of a loop, as described in section [2.2.3](#) and section [3.3](#). A loop occurs when a call is forked to a PBX that forks the call back, using a new SIP dialog.
- Enable a SIP UA to indicate that it is willing to receive an **SDP answer** through a non-reliable 183 provisional response to an **INVITE** message, as described in section [2.2.4](#) and section [3.4](#). Note that the standard recommends sending an SDP answer for **early media** only through a reliable provisional response, as described in [\[RFC3262\]](#).
- Define an anonymous phone URI, as described in section [2.2.5](#) and section [3.5](#), as an alternative to the standard anonymous SIP URI, as described in [\[RFC3261\]](#). Note that the standard anonymous SIP URI is not supported.
- Enable a SIP UA in the protocol network to indicate that it supports media bypass functionality, as described in section [2.2.6](#) and section [3.6](#). Media bypass has the media from the protocol network entity involved in a PSTN call going directly to the gateway used to interface with the PSTN for that call, without traversing any intermediate element in the protocol network.
- Enable a SIP UA in the protocol network to reference the appropriate **Session Description Protocol (SDP)** that was selected from a received **offer** when sending a **SIP message** with an **answer** to the offer, as described in section [2.2.7](#) and section [3.7](#).
- Identify the specific gateway used to interface with the PSTN for a PSTN call, as described in section [2.2.8](#) and section [3.8](#).

1.4 Relationship to Other Protocols

This protocol uses the protocols as described in [\[MS-SIPAE\]](#), [\[MS-SIPREGE\]](#), [\[MS-SIPRE\]](#), and [\[MS-SDPEXT\]](#) as well as the following Internet Engineering Task Force (IETF) Session Initiation Protocol (SIP) specifications:

- SIP: Session Initiation Protocol, as described in [\[RFC3261\]](#).
- Session Initiation Protocol (SIP): Locating SIP Servers, as described in [\[RFC3263\]](#).
- the Private Extensions to the Session Initiation Protocol (SIP) for Asserted Identity within Trusted Networks, as described in [\[RFC3325\]](#).
- the Session Initiation Protocol (SIP) Refer Method, as described in [\[RFC3515\]](#).
- the Session Initiation Protocol (SIP) "Replaces" Header, as described in [\[RFC3891\]](#).
- the Session Initiation Protocol (SIP) Referred-By Mechanism, as described in [\[RFC3892\]](#).
- an Offer/Answer Model with the Session Description Protocol (SDP), as described in [\[RFC3264\]](#).

1.5 Prerequisites/Preconditions

None.

1.6 Applicability Statement

This protocol is applicable for interfacing a protocol client with other traditional telephony networks, such as a PSTN and an enterprise PBX or IP-PBX.

1.7 Versioning and Capability Negotiation

This protocol does not have protocol versioning. Instead, explicit capability negotiation is done by using the **Supported** header to indicate support of various features. The **Supported** header is the standard SIP mechanism for doing capability negotiation.

1.8 Vendor-Extensible Fields

None.

1.9 Standards Assignments

None.

2 Messages

2.1 Transport

This protocol relies on SIP transport.

2.2 Message Syntax

This protocol uses the SIP message format, as specified in [\[RFC3261\]](#) section 7, and extends definitions of URI parameters and headers by adding new values for parameter and header names as well as their corresponding values.

2.2.1 isGateway

The **isGateway** parameter is defined by this protocol as a new **Contact** header field parameter. The original **Augmented Backus-Naur Form (ABNF)**, as defined in [\[RFC5234\]](#), for the **Contact** header field, as specified in [\[RFC3261\]](#) section 25, is extended as follows. The SIP **Contact** header field extension is the second line.

```
contact-params = c-p-q / c-p-expires
                / c-p-gw
                / contact-extension
c-p-gw = "isGateway"
```

The syntax of the **Contact** header field with the SIP **Contact** header field extension is illustrated as follows. The extension is the final `;isGateway`.

```
CONTACT: <sip:a@example.com;gruu;opaque=svr:MediationServer:xxx;grid=yyy>;isGateway
```

2.2.2 phone-context

This protocol extends the semantics of the *phone-context* parameter but does not change its syntax, as specified in [\[RFC3966\]](#). The *phone-context* value for a dial string is the provisioned location profile name of the user.

The *phone-context* extension defines the following two *phone-context* names:

- "dialstring"
- "enterprise"

The first one is used if a user location profile name is not provisioned, and the second is used if a SIP URI holds a phone number in a non-**E.164** format that is a result of applying enterprise **dial plan** rules.

The syntax of a SIP URI with a *phone-context* parameter is illustrated as follows:

```
sip:12345;phone-context=lp1@example.com;user=phone
```

In the previous line, `example.com` is the host part of the SIP URI. It is not affected by the *phone-context* parameter.

2.2.3 ms-call-source

The ABNF, as defined in [\[RFC5234\]](#), for the **ms-call-source** SIP header is as follows:

```
Ms-Call-Source = "Ms-Call-Source" HCOLON ("ms-rtc" / "non-ms-rtc")
```

The supported tokens for the **ms-call-source** header are "ms-rtc" and "non-ms-rtc". The first token designates that the call originated from a protocol server network, and the latter means that the call originated from a non-protocol server network, such as a PSTN or IP-PBX.

The syntax of this header is illustrated as follows:

```
Ms-Call-Source: ms-rtc
```

2.2.4 ms-early-media

The **ms-early-media** option tag is a proprietary option tag for the SIP **Supported** header, as specified in [\[RFC3261\]](#) section 20.37.

The syntax of the **ms-early-media** tag in the **Supported** header is illustrated as follows:

```
supported: ms-early-media
```

2.2.5 Anonymous Phone URI

The anonymous phone URI is an alternative to the standard anonymous SIP URI, as specified in [\[RFC3261\]](#). The user part of the SIP URI is set with the value "anonymous" and the parameter *user=phone* is added to the URI.

The syntax of a SIP URI with these settings is illustrated as follows:

```
sip:anonymous@contoso.com;user=phone
```

2.2.6 ms-bypass

The **ms-bypass** option tag is a proprietary option tag for the SIP **Supported** header, as specified in [\[RFC3261\]](#) section 20.37.

2.2.7 ms-accepted-content-id

The ABNF, as defined in [\[RFC5234\]](#), for the **ms-accepted-content-id** SIP header is as follows:

```
ms-accepted-content-id = "ms-accepted-content-id" HCOLON content-id
```

The **content-id** element is specified in [\[RFC2045\]](#) section 7 and [\[RFC2111\]](#) section 2. Note that the **ms-accepted-content-id** header includes the value of the **Content-ID MIME** header associated with the selected **SDP offer**.

The syntax of the **ms-accepted-content-id** header is illustrated as follows:

```
ms-accepted-content-id: <da6e05c91d6b4132afa14d8b528732e6>
```

2.2.8 ms-trunking-peer

The ABNF, as defined in [\[RFC5234\]](#), for the **ms-trunking-peer** SIP header is as follows:

```
ms-trunking-peer = "ms-trunking-peer" HCOLON host *1(SEMI trunkname) *1(SEMI User-Agent)
trunkname = "trunk" EQUAL hostname
```

The **host**, **hostname** and **User-Agent** elements are specified in [\[RFC3261\]](#) section 25.

The syntax of the **ms-trunking-peer** header is illustrated as follows:

```
ms-trunking-peer: gateway.companyl.com;trunk=trunk1;User-Agent="Gateway 1.0"
```

2.2.9 ms-mediation-generated

The ABNF, as defined in [\[RFC5234\]](#), for the **ms-mediation-generated** SIP header [<1>](#) is as follows:

```
ms-mediation-generated = "ms-mediation-generated" HCOLON "yes"
```

The syntax of the **ms-mediation-generated** header is illustrated as follows:

```
ms-mediation-generated: yes
```

3 Protocol Details

3.1 isGateway Details

UAC Behavior

If a UAC has a gateway role, it MUST insert the **isGateway** parameter in the **Contact** header. Otherwise, it MUST NOT insert this parameter in the **Contact** header.

UAS Behavior

If a UAS receives a SIP message with a **Contact** header that includes an **isGateway** parameter, it SHOULD render it to the application. The application MAY display this information to the user.

Proxy Behavior

This parameter does not affect a SIP proxy.

3.1.1 Abstract Data Model

None.

3.1.2 Timers

None.

3.1.3 Initialization

None.

3.1.4 Higher-Layer Triggered Events

None.

3.1.5 Message Processing Events and Sequencing Rules

None.

3.1.6 Timer Events

None.

3.1.7 Other Local Events

None.

3.2 phone-context Details

UAC Behavior

A UAC that is about to send an INVITE message to an address of a dial string MUST use the following logic. If a UAC cannot resolve the dial string to a SIP URI with an E.164 number of a remote party, based on local provisioning, it MUST set the SIP URI of the **Request URI** header with a phone number and a *phone-context* of the phone number in the user part of the SIP URI, as

specified in [\[RFC3966\]](#) section 5.1.5. The value of the *phone-context* SIP URI parameter holds the location profile name of the user if the dial string could not be resolved or the resolution of the dial string is to a non-E.164 number. If a user profile name is not provisioned and the dial string is not an E.164 number, the user agent MUST set *phone-context* to the default predefined **dialstring** name.

Callback presents another case where an outgoing call can have a **Request URI** and **To URI** containing a *phone-context* parameter. An incoming call to a UA can have a **P-Asserted-Identity (PAI)** header containing a non-E.164 number with a *phone-context* of "dialstring". Alternatively an incoming call to a UA can have a **P-Asserted-Identity** header containing a non-E.164 number with a *phone-context* of "enterprise". If the callback feature is implemented in the UA, the value of the **P-Asserted-Identity** header SHOULD be used to populate the **Request URI** and **To URI** fields in the INVITE triggered by the callback.

A UAC SHOULD [<2>](#) set a valid SIP URI in the **From** header. If the SIP URI is in a phone number format, `user=phone`, the phone number SHOULD [<3>](#) be in either E.164 format or a private number with a *phone-context* that is set with the location profile of the UAC.

UAS Behavior

If a UAS has a gateway role, it SHOULD include a **P-Asserted-Identity** in the **200 OK** that it sends in response to an initial INVITE used to establish a dialog. This 200 OK is derived by using the **Request URI** from the initial INVITE used to establish the dialog. If this **Request URI** is used, and it contains an E.164 number in the user part, the UAS SHOULD copy it to the PAI. If this **Request URI** is used, and it contains a non-E.164 number in the user part, the UAS SHOULD copy it to the P-Asserted-Identity (PAI) and the *phone-context* SHOULD be set to the location profile of the UAS.

Proxy Behavior

A SIP proxy that receives a SIP URI with a *phone-context* in the **Request URI** MUST try to match the *phone-context* name with a list of provisioned dial plan names. If there is a match, it MUST convert the SIP URI based on the rules that are defined in the matched dial plan. Otherwise if there is no match, it SHOULD use other proxy logic to route this URI.

A **P-Preferred-Identity** header is a SIP header field, as described in section 9.2 of [\[RFC3325\]](#), which carries the preferred identity for the user sending the SIP message. This header field is sent by a UA to a trusted proxy to be inserted as the value in the P-Asserted-Identity (PAI) header field.

A SIP proxy that receives an INVITE that contains a *phone-context* in the **From URI** SHOULD [<4>](#) try to match the *phone-context* name with a list of provisioned dial plan names. If there is a match, and the INVITE does not contain a P-Asserted-Identity (PAI) or **P-Preferred-Identity** header, the proxy SHOULD [<5>](#) apply the rules defined in the matched dial plan and add a P-Asserted-Identity (PAI) with the result of the translation. If the result of the translation is not an E.164 number, the proxy SHOULD [<6>](#) insert a *phone-context* with the value "enterprise".

3.2.1 Abstract Data Model

None.

3.2.2 Timers

None.

3.2.3 Initialization

None.

3.2.4 Higher-Layer Triggered Events

None.

3.2.5 Message Processing Events and Sequencing Rules

None.

3.2.6 Timer Events

None.

3.2.7 Other Local Events

None.

3.3 ms-call-source Details

UAC Behavior

If the UAC is a gateway, it MUST insert an **ms-call-source** header in the SIP INVITE message that is sent to a UAS with the value "non-ms-rtc".

If the UAC is a gateway, it MUST insert an **ms-call-source** header in the SIP INVITE message that is sent to the PSTN with the value "ms-rtc".

If the UAC is not a gateway, it MUST NOT insert an **ms-call-source** header in an INVITE message.

UAS Behavior

If a UAS receives an INVITE message with an **ms-call-source** header while in alerting state in another SIP dialog, it MUST reject the INVITE message with a 605 error code. Otherwise, it processes the INVITE as a regular INVITE message.

Proxy Behavior

If a SIP proxy receives an INVITE with an **ms-call-source** header and the call is forwarded to a different user based on the forwarding rules of the original user, it MUST strip the header.

If a SIP proxy receives an INVITE with an **ms-call-source** header and it forwards the INVITE to a user who is not provisioned to receive loop calls, as described in section [1.3](#), it MUST strip this header.

If a SIP proxy receives a 605 message to an INVITE message that includes the **ms-call-source header**, it MUST send back a 480 message to the previous hop.

3.3.1 Abstract Data Model

None.

3.3.2 Timers

None.

3.3.3 Initialization

None.

3.3.4 Higher-Layer Triggered Events

None.

3.3.5 Message Processing Events and Sequencing Rules

None.

3.3.6 Timer Events

None.

3.3.7 Other Local Events

None.

3.4 ms-early-media Details

UAC Behavior

If a UAC supports an SDP answer in a non-reliable 183 provisional response to an INVITE message, it **MUST** send a SIP **Supported** header with the **ms-early-media** option tag. The SDP content and the procedure for starting early media are specified in [\[MS-SDPEXT\]](#) section 3.1.5.12.

UAS Behavior

A UAS with a gateway role that receives an INVITE with a **Supported** header that includes an **ms-early-media** option tag **MUST** send an unreliable 183 provisional response with an SDP answer. The SDP content and the procedure for starting early media are specified in [\[MS-SDPEXT\]](#) section 3.1.5.12.

A UAS with a non-gateway role that receives an INVITE with a **Supported** header that includes an **ms-early-media** option tag **MAY** send an unreliable 183 provisional response with an SDP answer. The SDP content and the procedure for starting early media are specified in [\[MS-SDPEXT\]](#) section 3.1.5.12.

Proxy Behavior

There is no special handling for this extension for a SIP proxy.

3.4.1 Abstract Data Model

None.

3.4.2 Timers

None.

3.4.3 Initialization

None.

3.4.4 Higher-Layer Triggered Events

None.

3.4.5 Message Processing Events and Sequencing Rules

None.

3.4.6 Timer Events

None.

3.4.7 Other Local Events

None.

3.5 Anonymous Phone URI Details

The special URI "anonymous@host;user=phone" in the **From** header field MUST be used to denote an anonymous user. [<7>](#) The *host* portion contains the IP address, **fully qualified domain name (FQDN) (1)**, or **domain** of the user. The encoding for an anonymous user that uses "anonymous.invalid" in the *host* portion MUST NOT be used.

3.5.1 Abstract Data Model

None.

3.5.2 Timers

None.

3.5.3 Initialization

None.

3.5.4 Higher-Layer Triggered Events

None.

3.5.5 Message Processing Events and Sequencing Rules

None.

3.5.6 Timer Events

None.

3.5.7 Other Local Events

None.

3.6 ms-bypass Details

A user agent (UA) supporting media bypass SHOULD [<8>](#) include a Session Initiation Protocol (SIP) **Supported** header with the **ms-bypass** option tag whenever it advertises the options it supports. Media bypass has the media from the protocol network entity involved in a public switched telephone network (PSTN) call going directly to the gateway used to interface with the PSTN for that call, without traversing any intermediate element in the protocol network.

3.6.1 Abstract Data Model

None.

3.6.2 Timers

None.

3.6.3 Initialization

None.

3.6.4 Higher-Layer Triggered Events

None.

3.6.5 Message Processing Events and Sequencing Rules

None.

3.6.6 Timer Events

None.

3.6.7 Other Local Events

None.

3.7 ms-accepted-content-id Details

This section describes the **ms-accepted-content-id** SIP header. [<9>](#)

UAC Behavior

A UAC MUST include a **Content-ID MIME** header with each **Multipurpose Internet Mail Extensions (MIME)** type of "application/SDP" and "application/gw-sdp" that it sends in an offer. The SDP content is specified in [\[MS-SDPEXT\]](#) section 3.

UAS Behavior

A UAS MUST include an **ms-accepted-content-id** SIP header in a SIP message containing an SDP answer if the selected SDP from the offer with which the answer is associated contained a **Content-ID MIME** header. The value of the **Content-ID MIME** header from the selected SDP in the offer MUST be copied as the value for the **ms-accepted-content-id** header.

3.7.1 Abstract Data Model

None.

3.7.2 Timers

None.

3.7.3 Initialization

None.

3.7.4 Higher-Layer Triggered Events

None.

3.7.5 Message Processing Events and Sequencing Rules

None.

3.7.6 Timer Events

None.

3.7.7 Other Local Events

None.

3.8 ms-trunking-peer Details

The **ms-trunking-peer** Session Initiation Protocol (SIP) header is included by a SIP UA that has a gateway role. It is used to identify the specific gateway used to interface with the public switched telephone network (PSTN) for a PSTN call. [<10>](#)

3.8.1 Abstract Data Model

None.

3.8.2 Timers

None.

3.8.3 Initialization

None.

3.8.4 Higher-Layer Triggered Events

None.

3.8.5 Message Processing Events and Sequencing Rules

None.

3.8.6 Timer Events

None.

3.8.7 Other Local Events

None.

3.9 ms-mediation-generated Details

The **ms-mediation-generated** Session Initiation Protocol (SIP) header is included by a SIP UA that has a gateway role. [<11>](#) It is used in provisional responses to indicate that the response was auto-generated by the UA and is not forwarded from a gateway used to interface with the public switched telephone network (PSTN) for a PSTN call.

3.9.1 Abstract Data Model

None.

3.9.2 Timers

None.

3.9.3 Initialization

None.

3.9.4 Higher-Layer Triggered Events

None.

3.9.5 Message Processing Events and Sequencing Rules

None.

3.9.6 Timer Events

None.

3.9.7 Other Local Events

None.

4 Protocol Examples

4.1 isGateway SIP Contact Header Parameter

4.1.1 Inbound Call

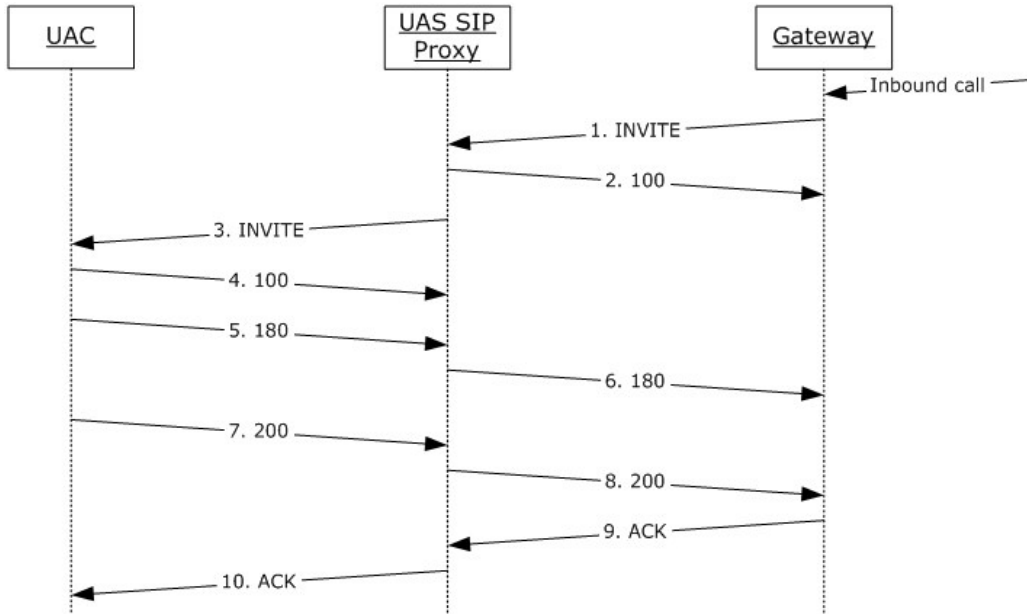

Figure 2: Inbound call

The preceding figure includes only one message in each direction because other messages repeat the same values.

The messages in the following subsections illustrate the use of the **Contact** header **isGateway** parameter in messages that are sent from and received by a protocol client.

4.1.1.1 Step 3: INVITE Message Is Received by the UAC

```
INVITE sip:10.56.66.167:1501;transport=tls;ms-opaque=56d3073f52;ms-received-cid=8000 SIP/2.0
Record-Route: <sip:server1.example.com:5061;transport=tls;ms-role-rs-from;lr;ms-identity=C8ybl0ausk5JrrJOeabpGevnl7YoohtFBsEB30y33pmWwR9xH_oTAlgAA;ms-route-sig=ea0mlvIX8ijETotqsV9nVQESDR_2qwR9xH_oTAlgAA>;tag=D78DE2B2FF72EB24FDA98B88DCC879B2
Via: SIP/2.0/TLS 10.56.64.202:5061;branch=z9hG4bKD262F853.B047DC47;branched=TRUE;ms-internal-info="daqI8a1fcNqkUHDJyMoUxdQuDrDTCwR9xH7_OEdQAA"
Authentication-Info: Kerberos
rspauth="602306092A864886F71201020201011100FFFFFFFF1125B31E1322F6E6A4E65212D8DEDCA4",
srand="A8085D66", snum="58", opaque="C216B7E9", qop="auth",
targetname="sip/media.example.com", realm="SIP Communications Service"
Max-Forwards: 69
Content-Length: 1606
Via: SIP/2.0/TLS 10.56.64.207:2861;branch=z9hG4bK27555a4e;ms-received-port=2861;ms-received-cid=8900
From: <sip:anonymous@server1.example.com;user=phone>;epid=571F84BB45;tag=ed77bad0f0
To: <sip:7275036;phone-context=normal-loc@server1.example.com;user=phone>;epid=782abb8f70
CSeq: 6 INVITE
Call-ID: 46bac89b-3f5f-4f1f-bb0b-e791706e2401
```

Contact:
<sip:server1.example.com@server1.example.com;gruu;opaque=srvr:MediationServer:ANaNrdcy8EmB-dKmljqX-wAA;grid=9b192c6b829d4373adb88ea9ef4dff03>;isGateway
Supported: replaces
Supported: gruu-10
User-Agent: RTCC/3.0.0.0 MediationServer
Content-Type: application/sdp; charset=utf-8

4.1.1.2 Step 7: 200 Message Is Sent from the UAC

```
SIP/2.0 200 OK
Via: SIP/2.0/TLS 10.56.64.202:5061;branch=z9hG4bKD262F853.B047DC47;branched=TRUE;ms-internal-
info="daqI8a1fcNqkUHDJyMoUxdQuDrDTCwR9xH7_OEdQAA"
Via: SIP/2.0/TLS 10.56.64.207:2861;branch=z9hG4bK27555a4e;ms-received-port=2861;ms-received-
cid=8900
From: <sip:anonymous@server1.example.com;user=phone>;epid=571F84BB45;tag=ed77bad0f0
To: "" <sip:7275036;phone-context=normal-
loc@server1.example.com;user=phone>;epid=782abb8f70;tag=8827660e0c
Call-ID: 46bac89b-3f5f-4f1f-bb0b-e791706e2401
CSeq: 6 INVITE
Record-Route: <sip:server1.example.com:5061;transport=tls;ms-role-rs-from;lr;ms-
identity=C8ybl0ausk5JrrJOeabpGevnl7YoohctFBsEB3Oy33pmWwR9xH_oTAlgAA;ms-route-
sig=ea0mlvIX8ijETotqsV9nVQESDR_2qwr9xH_oTAlgAA>;tag=D78DE2B2FF72EB24FDA98B88DCC879B2
Contact: <sip:alice@server1.example.com;opaque=user:epid:reTyjuqAaVmcCIO4qlA4vwAA;gruu>
User-Agent: UCCP/2.0.6362.0 OC/2.0.6362.0 (Client)
P-Preferred-Identity: <sip:alice@server1.example.com>, <tel:+15555550103>
Proxy-Authorization: Kerberos qop="auth", realm="SIP Communications Service",
opaque="C216B7E9", crand="dde2ad45", cnum="44", targetname="sip/server1.example.com",
response="602306092a864886f71201020201011100fffffffff77de9d7a16f9693a9cc29ed8d6735499"
Content-Type: application/sdp
```

4.1.2 Outbound Call

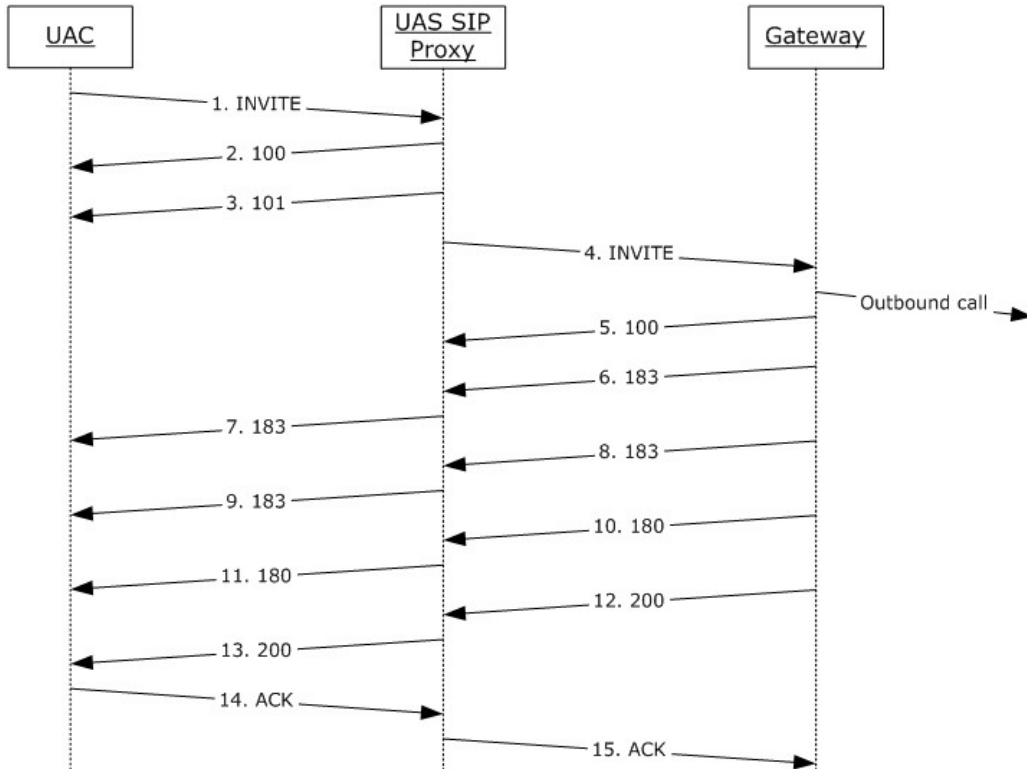

Figure 3: Outbound call

The preceding figure includes only one message in each direction because other messages repeat the same values.

The messages in the following subsections illustrate the use of the **Contact** header **isGateway** parameter in messages that are sent from and received by a UAC.

4.1.2.1 Step 1: INVITE Message Is Sent from the UAC

```
INVITE sip:+15555550103@server1.example.com;user=phone SIP/2.0
Via: SIP/2.0/TLS 10.56.66.167:1501
Max-Forwards: 70
From: <sip:alice@server1.example.com>;tag=85e83db3c6;epid=782abb8f70
To: <sip:+15555550103@server1.example.com;user=phone>
Call-ID: accd397afad9439d880f45cfce04bd66
CSeq: 1 INVITE
Contact: <sip:alice@server1.example.com;opaque=user:epid:reTyjuqAaVmcCIO4qlA4vwAA;gruu>
User-Agent: UCCP/2.0.6362.0 OC/2.0.6362.0 (Client)
Ms-Conversation-ID: AchdT5LJJvFktNrrSjejQUAy0wgfoA==
Supported: timer
Supported: ms-sender
Supported: ms-early-media
ms-keep-alive: UAC;hop-hop=yes
P-Preferred-Identity: <sip:alice@server1.example.com>, <tel:+15555550103>
Supported: ms-conf-invite
```

```
Proxy-Authorization: Kerberos qop="auth", realm="SIP Communications Service",
opaque="C216B7E9", crand="aeee0f50", cnum="35", targetname="sip/server1.example.com",
response="602306092a864886f71201020201011100fffffffffec51ac48141bf21d6a1487eaca68cca6"
Content-Type: application/sdp
Content-Length: 1076
```

4.1.2.2 Step 12: 200 Message Is Received by the UAC

```
SIP/2.0 200 OK
Authentication-Info: Kerberos
rspauth="602306092A864886F71201020201011100FFFFFFFF0714800DE2F658803052D07C86052224",
srand="B997073B", snum="50", opaque="C216B7E9", qop="auth",
targetname="sip/server1.example.com", realm="SIP Communications Service"
Via: SIP/2.0/TLS 10.56.66.167:1501;ms-received-port=1501;ms-received-cid=8000
FROM: "alice"<sip:alice@server1.example.com>;tag=85e83db3c6;epid=782abb8f70
TO: <sip:+15555550103@server1.example.com;user=phone>;epid=571F84BB45;tag=a0f83282b
CSEQ: 1 INVITE
CALL-ID: accd397afad9439d880f45cfce04bd66
RECORD-ROUTE: <sip:server1.example.com:5061;transport=tls;ms-role-rs-from;lr;ms-route-
sig=eab5PYPD_tLMiadtWiQ5tem-72y4vocRve_oTAlgAA>
CONTACT:
<sip:server1.example.com@server1.example.com;gruu;opaque=srvr:MediationServer:ANaNrdcy8EmB-
dKmljqX-wAA;grid=439be8c54ef04ce0baa8842286f86c53>;isGateway
CONTENT-LENGTH: 1412
SUPPORTED: gruu-10
SUPPORTED: replaces
CONTENT-TYPE: application/sdp; charset=utf-8
ALLOW: UPDATE
P-ASSERTED-IDENTITY: <sip:+15555550103@server1.example.com;user=phone>
SERVER: RTCC/3.0.0.0 MediationServer
ALLOW: Ack, Cancel, Bye, Invite, Refer
```

4.2 phone-context SIP URI Parameter

4.2.1 Inbound Call

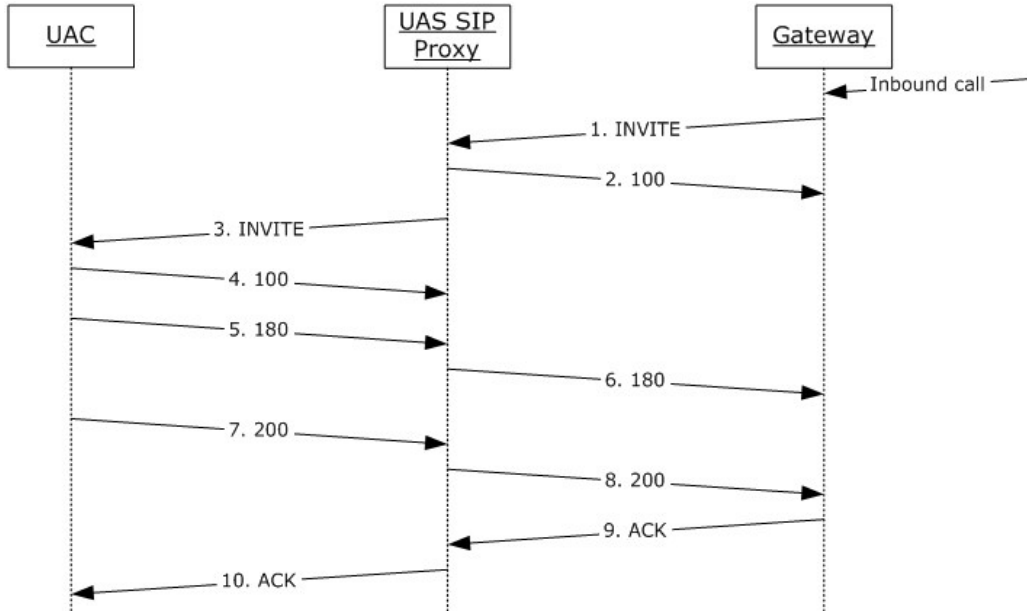

Figure 4: Inbound call

The preceding figure includes one message in each direction because other messages repeat the same values.

The messages in the following subsections illustrate the use of the *phone-context* parameter in messages that are sent from and received by the UAC.

4.2.1.1 Step 3: INVITE Message Is Received by the UAC

A UAS proxy replaces the **Request URI** header with the *phone-context* parameter that is received from the gateway. However, the **To** header is not replaced and holds the SIP URI with the *phone-context* that was inserted by the gateway.

```
INVITE sip:10.56.66.167:1501;transport=tls;ms-opaque=56d3073f52;ms-received-cid=8000 SIP/2.0
Record-Route: <sip:server1.example.com:5061;transport=tls;ms-role-rs-from;lr;ms-identity=C8ybl0ausk5JrrJOeabpGevnl7YoohtctFBsEB3Oy33pmWwR9xH_oTAlgAA;ms-route-sig=ea0mlvIX8ijETotqsV9nVQESDR_2qWR9xH_oTAlgAA>;tag=D78DE2B2FF72EB24FDA98B88DCC879B2
Via: SIP/2.0/TLS 10.56.64.202:5061;branch=z9hG4bKD262F853.B047DC47;branched=TRUE;ms-internal-info="daqI8alfcNQkUHDJyMoUxdQudrDTCwR9xH7_OEdQAA"
Authentication-Info: Kerberos
rspauth="602306092A864886F71201020201011100FFFFFFFF1125B31E1322F6E6A4E65212D8DEDCA4",
srand="A8085D66", snum="58", opaque="C216B7E9", qop="auth",
targetname="sip/server1.example.com", realm="SIP Communications Service"
Max-Forwards: 69
Content-Length: 1606
Via: SIP/2.0/TLS 10.56.64.207:2861;branch=z9hG4bK27555a4e;ms-received-port=2861;ms-received-cid=8900
From: <sip:+15555550103@server1.example.com;user=phone>;epid=571F84BB45;tag=ed77bad0f0
To: <sip:7275036;phone-context=normal-loc@server1.example.com;user=phone>;epid=782abb8f70
```

CSeq: 6 INVITE
Call-ID: 46bac89b-3f5f-4f1f-bb0b-e791706e2401
Contact:
<sipserver1.example.com@server1.example.com;gruu;opaque=srvr:MediationServer:ANaNrncy8EmB-dKmljqX-wAA;grid=9b192c6b829d4373adb88ea9ef4dff03>;isGateway
Supported: replaces
Supported: gruu-10
User-Agent: RTCC/3.0.0.0 MediationServer
Content-Type: application/sdp; charset=utf-8

4.2.1.2 Step 7: 200 Message Is Sent from the UAC

SIP/2.0 200 OK
Via: SIP/2.0/TLS 10.56.64.202:5061;branch=z9hG4bKD262F853.B047DC47;branched=TRUE;ms-internal-info="daqI8alfcNQkUHDJyMoUxdQuDrDTCwR9xH7_OEdQAA"
Via: SIP/2.0/TLS 10.56.64.207:2861;branch=z9hG4bK27555a4e;ms-received-port=2861;ms-received-cid=8900
From: <sip:+15555550103@server1.example.com;user=phone>;epid=571F84BB45;tag=ed77bad0f0
To: "" <sip:7275036;phone-context=normal-loc@server1.example.com;user=phone>;epid=782abb8f70;tag=8827660e0c
Call-ID: 46bac89b-3f5f-4f1f-bb0b-e791706e2401
CSeq: 6 INVITE
Record-Route: <sip:server1.example.com:5061;transport=tls;ms-role-rs-from;lr;ms-identity=C8ybl0ausk5JrrJOeabpGevnl7YoohtFBsEB30y33pmWwR9xH_oTAlgAA;ms-route-sig=ea0mlvIX8ijETotqsV9nVQESDR_2qwR9xH_oTAlgAA>;tag=D78DE2B2FF72EB24FDA98B88DCC879B2
Contact: <sip:alice@server1.example.com;opaque=user:epid:reTyjuqAaVmCtIO4qlA4vwAA;gruu>
User-Agent: UCCP/2.0.6362.0 OC/2.0.6362.0 (Client)
P-Preferred-Identity: <sip:alice@server1.example.com>, <tel:+15555550106>
Proxy-Authorization: Kerberos qop="auth", realm="SIP Communications Service", opaque="C216B7E9", crand="dde2ad45", cnum="44", targetname="sip/server1.example.com", response="602306092a864886f71201020201011100ffffffff77de9d7a16f9693a9cc29ed8d6735499"
Content-Type: application/sdp

4.2.2 Outbound Call

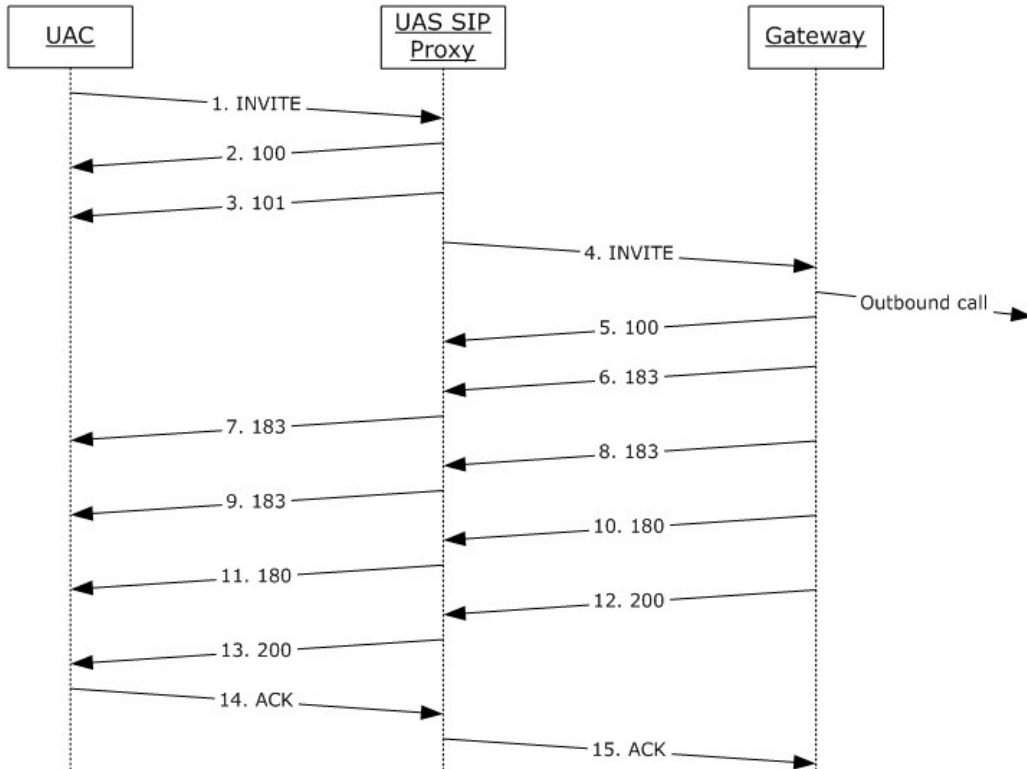

Figure 5: Outbound call

The preceding figure includes one message in each direction because other messages repeat the same values.

The messages in the following subsections illustrate the use of the *phone-context* parameter in messages that are sent from and received by a UAC.

4.2.2.1 Step 1: INVITE Message Is Sent from the UAC

```
INVITE sip:72181;phone-context=dialstring@example.com;user=phone SIP/2.0
Via: SIP/2.0/TLS 10.56.64.148:4031
Max-Forwards: 70
From: <sip:test2@example.com>;tag=cefe741803;epid=7d725e08a1
To: <sip:72181;phone-context=dialstring@example.com;user=phone>
Call-ID: a6a53b0e3b7d40a3b445dc4d9249b6fe
CSeq: 1 INVITE
Contact: <sip:test2@example.com;opaque=user:epid:00NaA0AXIFCRDgr367kcHwAA;gruu>
User-Agent: UCCP/2.0.6362.36 OC/2.0.6362.36 (Client)
Ms-Conversation-ID: Achis3b6kqiLEhnZR/+DMH2N7C09hg==
Supported: timer
Supported: ms-sender
Supported: ms-early-media
ms-keep-alive: UAC;hop-hop=yes
P-Preferred-Identity: <sip:test2@example.com>, <tel:+15555550100>
Supported: ms-conf-invite
```

Proxy-Authorization: NTLM qop="auth", realm="SIP Communications Service", opaque="9ACB05CE",
crand="05c62674", cnum="10", targetname="server1.example.com",
response="01000000b09f0702d4e4e934e25e6f9b"
Content-Type: application/sdp

4.2.2.2 Step 12: 200 Message Is Received by the UAC

SIP/2.0 200 OK
Authentication-Info: NTLM rspauth="01000000653865359728F3C8E25E6F9B", srand="8A3F6211",
snum="19", opaque="9ACB05CE", qop="auth", targetname="server1.example.com", realm="SIP
Communications Service"
Via: SIP/2.0/TLS 10.56.64.148:4031;ms-received-port=4031;ms-received-cid=500
FROM: "test2"<sip:test2@example.com>;tag=cefe741803;epid=7d725e08a1
TO: <sip:72181;phone-
context=dialstring@example.com;user=phone>;epid=6477F45221;tag=a5c53ff9d6
CSEQ: 1 INVITE
CALL-ID: a6a53b0e3b7d40a3b445dc4d9249b6fe
RECORD-ROUTE: <sip:server1.example.com:5061;transport=tls;ms-role-rs-from;lr;ms-route-
sig=aaabLHUMznhhFXTzutN9dwpQ-RmwQYZA_UIeytlQAA>
CONTACT: <sip:SH13-
LCT.example.com@example.com;gruu;opaque=srvr:MediationServer:TIRig7bu5kGXhNJb1ZwQfgAA;grid=f1
f9379bd9334f65aaldfb77bed58905>;isGateway
CONTENT-LENGTH: 740
SUPPORTED: gruu-10
SUPPORTED: replaces
CONTENT-TYPE: application/sdp; charset=utf-8

4.3 ms-call-source SIP Header

4.3.1 Inbound Call

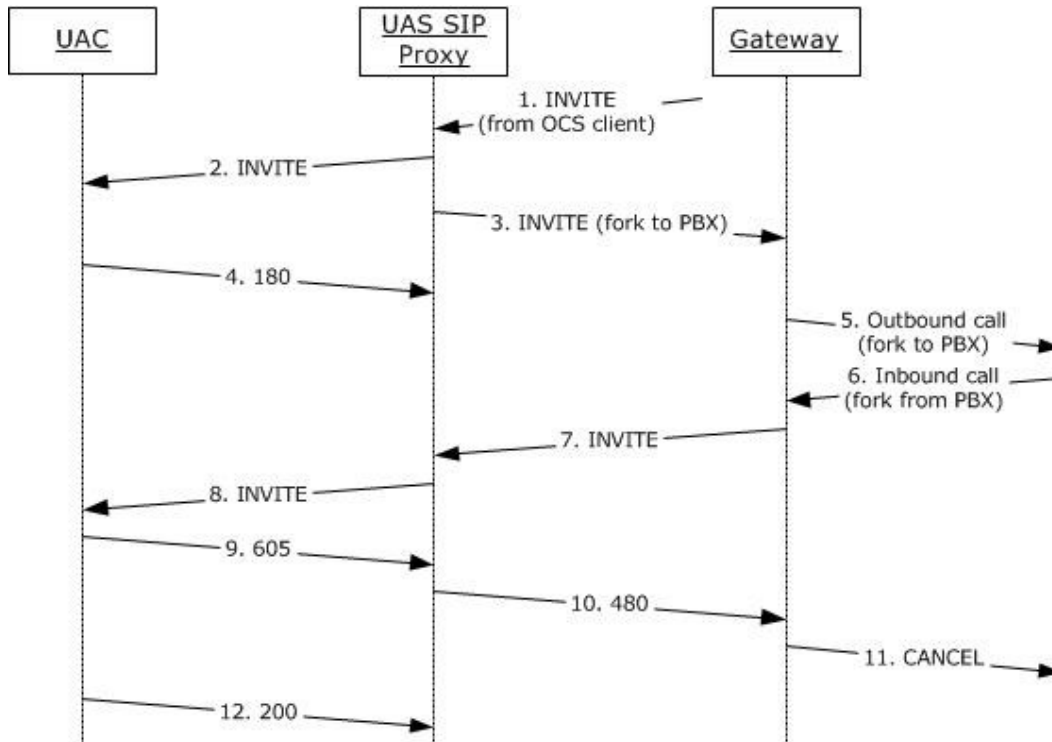

Figure 6: Inbound call

The preceding figure includes only key messages that are described in this section.

The messages in the following subsections illustrate the use of the **ms-call-source** header in messages that are sent from and received by a UAC.

4.3.1.1 Step 2: INVITE Message Is Received by the UAC

This call originates from a protocol client; therefore, it does not include an **ms-call-source** header.

```
INVITE sip:10.56.66.167:3080;transport=tls;ms-opaque=0e2b3bcc10;ms-received-cid=300 SIP/2.0
Record-Route: <sip:server1.example.com:5061;transport=tls;ms-role-rs-to;ms-role-rs-
from;lr;ms-route-sig=aalPYPSx-
ubLAoi5ZiOqMhLgC0U3l0xkBBiLt2WZQAA>;tag=8951c70c798e10ea48eb96eaa4b379bc
Via: SIP/2.0/TLS 172.29.106.3:5061;branch=z9hG4bK76F2CFD5.31901062;branched=TRUE;ms-internal-
info="aac8UGYE_vlAjm36glJ1-v1NQi15UxkBBihbkIPAAA"
Authentication-Info: NTLM rspauth="0100000044415441c22e2f66f9c08f09", srand="4CB6D6F5",
snum="31", opaque="FB347BC6", qop="auth", targetname="server1.example.com", realm="SIP
Communications Service"
Max-Forwards: 69
Content-Length: 1074
Via: SIP/2.0/TLS 10.56.64.148:3981;ms-received-port=3981;ms-received-cid=200
P-Asserted-Identity: "test2"<sip:test2@example.com>, <tel:+15555550100>
From: "test2"<sip:test2@example.com>;tag=08399379aa;epid=7d725e08a1
To: <sip:test1@example.com>;epid=782abb8f70
```



```
Call-ID: ee22d219e9f44441bbac7b304ddc1096
CSeq: 1 INVITE
Contact: <sip:test2@example.com;opaque=user:epid:00NaA0AXIFCRDgr367kcHwAA;gruu>
User-Agent: UCCP/2.0.6362.36 OC/2.0.6362.36 (Client)
Ms-Conversation-ID: AchisczVZkuxUO7mTZieBaNoXIHJ8g==
Supported: timer
Supported: ms-sender
Supported: ms-early-media
ms-keep-alive: UAC;hop-hop=yes
Supported: ms-conf-invite
Content-Type: application/sdp
```

4.3.1.2 Step 8: INVITE Message Is Received by the UAC

This call originates from the private branch exchange (PBX); therefore, it includes an **ms-call-source** header.

```
INVITE sip:10.56.66.167:3080;transport=tls;ms-opaque=0e2b3bcc10;ms-received-cid=300 SIP/2.0
Record-Route: <sip:server1.example.com:5061;transport=tls;ms-role-rs-from;lr;ms-identity=B5buGzyhwo49ocK0aabbgxdAqaQRu_k9cZxy4WI-659Sq6MHw6Lt2WZQAA;ms-route-sig=aa30eh935IYJmaV5AyTn4katb_Zd-6MHw6Lt2WZQAA>;tag=8951C70C798E10EA48EB96EAA4B379BC
Via: SIP/2.0/TLS 172.29.106.3:5061;branch=z9hG4bKD300E89E.BA307C3A;branched=TRUE;ms-internal-info="aaKlz4lwQeqhL-R5X7wnN8hEhuJwK6MHw6hbkIPAAA"
Authentication-Info: NTLM rspauth="0100000000000000A761D372F9C08F09", srand="51ED7291", snum="32", opaque="FB347BC6", qop="auth", targetname="server1.example.com", realm="SIP Communications Service"
Max-Forwards: 69
Content-Length: 934
Via: SIP/2.0/TLS 10.198.92.126:4757;branch=z9hG4bK557e25e3;ms-received-port=4757;ms-received-cid=700
From: <sip:2160;phone-context=dialstring@example.com;user=phone>;epid=6477F45221;tag=a3a3579bb
To: <sip:+15555550108@example.com;user=phone>;epid=782abb8f70
CSeq: 179 INVITE
Call-ID: 729ab37d-c0f5-4ad7-b7e0-8f3dad99065
Contact: <sip:SH13-LCT.example.com@example.com;gruu;opaque=srvr:MediationServer:TIRig7bu5kGXhNJB1zWqfgAA;grid=2c fb52f9fd4b4930a6f0a82dbfcd39e4>;isGateway
Supported: replaces
Supported: gruu-10
User-Agent: RTCC/3.0.0.0 MediationServer
Content-Type: application/sdp; charset=utf-8
Allow: UPDATE
Allow: Ack, Cancel, Bye, Invite, Refer
Ms-Call-Source: non-ms-rtc
```

4.3.1.3 Step 9: 605 Message Is Sent from the UAC

This INVITE is rejected with a 605 Decline because it originated as a result of a loop in the private branch exchange (PBX).

```
SIP/2.0 605 Decline Everywhere
Via: SIP/2.0/TLS 172.29.106.3:5061;branch=z9hG4bKD300E89E.BA307C3A;branched=TRUE;ms-internal-info="aaKlz4lwQeqhL-R5X7wnN8hEhuJwK6MHw6hbkIPAAA"
Via: SIP/2.0/TLS 10.198.92.126:4757;branch=z9hG4bK557e25e3;ms-received-port=4757;ms-received-cid=700
```

```
From: <sip:2160;phone-  
context=dialstring@example.com;user=phone>;epid=6477F45221;tag=a3a3579bb  
To: "" <sip:+15555550108@example.com;user=phone>;epid=782abb8f70;tag=b9bc5b444c  
Call-ID: 729ab37d-c0f5-4ad7-b7e0-8f3dad99065  
CSeq: 179 INVITE  
Record-Route: <sip:server1.example.com:5061;transport=tls;ms-role-rs-from;lr;ms-  
identity=B5buGzyhwo49ocKOaabbgxdAqaQRu_k9cZxy4WI-659Sq6MHw6Lt2WZQAA;ms-route-  
sig=aa30eh935IYJmaV5AyTn4katb_Zd-6MHw6Lt2WZQAA>;tag=8951C70C798E10EA48EB96EAA4B379BC  
User-Agent: UCCP/2.0.6362.0 OC/2.0.6362.0 (Client)  
Ms-client-diagnostics: 52034; reason="Rejected Duplicate call from PBX"  
Proxy-Authorization: NTLM qop="auth", realm="SIP Communications Service", opaque="FB347BC6",  
crand="b062a12e", cnum="29", targetname="server1.example.com",  
response="0100000730069006642f8a9f9c08f09"  
Content-Length: 0
```

4.3.1.4 Step 12: 200 Message Is Sent from the UAC

The first INVITE from a protocol client is accepted and the following 200 OK is sent.

```
SIP/2.0 200 OK  
Via: SIP/2.0/TLS 172.29.106.3:5061;branch=z9hG4bK76F2CFD5.31901062;branched=TRUE;ms-internal-  
info="aac8UGYE_vlAjm36glJ1-vlNQi15UxkBBihbkIPAAA"  
Via: SIP/2.0/TLS 10.56.64.148:3981;ms-received-port=3981;ms-received-cid=200  
From: "test2"<sip:test2@example.com>;tag=08399379aa;epid=7d725e08a1  
To: "" <sip:test1@example.com>;epid=782abb8f70;tag=281b612cd0  
Call-ID: ee22d219e9f44441bbac7b304ddc1096  
CSeq: 1 INVITE  
Record-Route: <sip:server1.example.com:5061;transport=tls;ms-role-rs-to;ms-role-rs-  
from;lr;ms-route-sig=aalPYPSx-  
ubLAoi5ZiOqMHLGcU3l0xkBBiLt2WZQAA>;tag=8951C70C798E10EA48EB96EAA4B379BC  
Contact: <sip:test1@example.com;opaque=user:epid:reTyjuqAaVmcCIO4qlA4vwAA;gruu>  
User-Agent: UCCP/2.0.6362.0 OC/2.0.6362.0 (Client)  
P-Preferred-Identity: <sip:test1@example.com>, <tel:+15555550100>  
Proxy-Authorization: NTLM qop="auth", realm="SIP Communications Service", opaque="FB347BC6",  
crand="1b602324", cnum="30", targetname="server1.example.com",  
response="010000006895aa03478d7d34f9c08f09"  
Content-Type: application/sdp
```

4.3.2 Outbound Call

The **ms-call-source** header is not sent or received by a UAC in this scenario.

4.4 ms-early-media SIP Supported Header Option Tag

4.4.1 Inbound Call

The **ms-early-media** tag is not sent or received by a UAC in this scenario.

4.4.2 Outbound Call

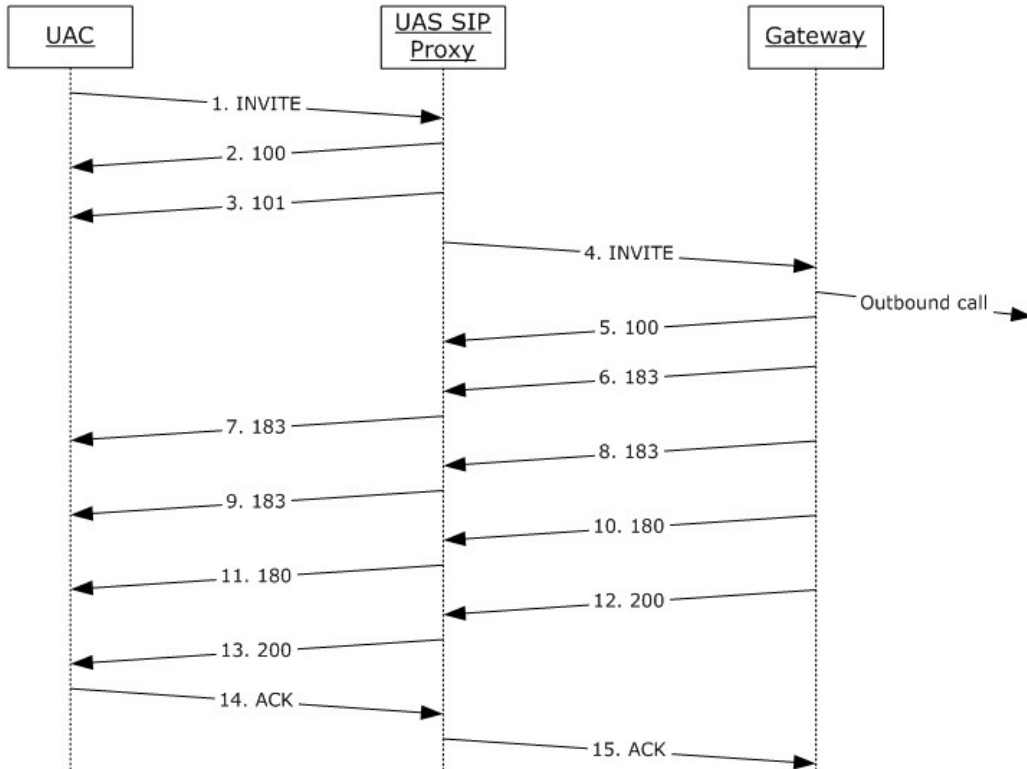

Figure 7: Outbound call

The preceding figure includes only key messages that are described in this section.

The following messages illustrate the use of the **ms-early-media** option tag in messages that are sent from and received by a UAC.

4.4.2.1 Step 1: INVITE Is Sent from the UAC

The following INVITE includes an **ms-early-media** option tag in a **Supported** header and an SDP offer.

```
INVITE sip:+15555550100@example.com;user=phone SIP/2.0
Via: SIP/2.0/TLS 10.56.66.167:3137
Max-Forwards: 70
From: <sip:test1@example.com>;tag=2b95504d65;epid=782abb8f70
To: <sip:+15555550100@example.com;user=phone>
Call-ID: ca22890914c34bf8a7439dfe1e834420
CSeq: 1 INVITE
Contact: <sip:test1@example.com;opaque=user:epid:reTyjuqAaVmcCIO4qlA4vwAA;gruu>
User-Agent: UCCP/2.0.6362.0 OC/2.0.6362.0 (Client)
Ms-Conversation-ID: Achit1o1q5CCFcXhrKeZABfaZzvWNw==
Supported: timer
Supported: ms-sender
Supported: ms-early-media
ms-keep-alive: UAC;hop-hop=yes
```

```

P-Preferred-Identity: <sip:test1@example.com>, <tel:+15555550101>
Supported: ms-conf-invite
Proxy-Authorization: NTLM qop="auth", realm="SIP Communications Service", opaque="B25450B8",
crand="620d1d6e", cnum="79", targetname="server1.example.com",
response="0100000008aab30387f6e10ef27db686"
Content-Type: application/sdp
Content-Length: 1076
v=0
o=- 0 0 IN IP4 10.56.66.167
s=session
c=IN IP4 10.56.66.167
b=CT:99980
t=0 0
m=audio 50016 RTP/AVP 114 111 112 115 116 4 8 0 97 101
k=base64:BCw/3c0RQ/ndiix3QiLgO9s3z1ZhEcLU3ZC85C74zuNSmyIrx1leIA4kErwh
a=candidate:Hfb3G/XvuV5G7gXYnDfWjyyZ8aIUbsPUhQRkndBg3vU 1 x4Ykst3u0Cf7mAW0moKnMQ UDP 0.900
10.56.66.167 50016
a=candidate:Hfb3G/XvuV5G7gXYnDfWjyyZ8aIUbsPUhQRkndBg3vU 2 x4Ykst3u0Cf7mAW0moKnMQ UDP 0.900
10.56.66.167 50008
a=cryptoscale:1 client AES_CM_128_HMAC_SHA1_80
inline:aAzhJhKx1bOgjuVWNfI8C4f1K9lE5SJt6vFTAWP|2^31|1:1
a=crypto:2 AES_CM_128_HMAC_SHA1_80 inline:VqAkQvuZOMKH1uaXvi+8kjiJlRsiyngtcuh2AA5k|2^31|1:1
a=maxptime:200
a=rtcp:50008
a=rtpmap:114 x-msrta/16000
a=fmtp:114 bitrate=29000
a=rtpmap:111 SIREN/16000
a=fmtp:111 bitrate=16000
a=rtpmap:112 G7221/16000
a=fmtp:112 bitrate=24000
a=rtpmap:115 x-msrta/8000
a=fmtp:115 bitrate=11800
a=rtpmap:116 AAL2-G726-32/8000
a=rtpmap:4 G723/8000
a=rtpmap:8 PCMA/8000
a=rtpmap:0 PCMU/8000
a=rtpmap:97 RED/8000
a=rtpmap:101 telephone-event/8000
a=fmtp:101 0-16
a=encryption:optional

```

4.4.2.2 Step 7: 183 Message Is Received by the UAC

The following 183 Session Progress message includes an SDP answer.

```

SIP/2.0 183 Session Progress
Authentication-Info: NTLM rspauth="010000000000000008AC67ADF27DB686", srand="DF9D53C4",
snum="103", opaque="B25450B8", qop="auth", targetname="server1.example.com", realm="SIP
Communications Service"
Via: SIP/2.0/TLS 10.56.66.167:3137;ms-received-port=3137;ms-received-cid=100
FROM: "test1"<sip:test1@example.com>;tag=2b95504d65;epid=782abb8f70
TO: <sip:+15555550100@example.com;user=phone>;epid=6477F45221;tag=b5bb1243e3
CSEQ: 1 INVITE
CALL-ID: ca22890914c34bf8a7439dfe1e834420
CONTENT-LENGTH: 740
CONTENT-TYPE: application/sdp; charset=utf-8
SERVER: RTCC/3.0.0.0 MediationServer
v=0

```

```

o=- 0 0 IN IP4 10.198.92.126
s=session
c=IN IP4 10.198.92.126
b=CT:1000
t=0 0
m=audio 60625 RTP/SAVP 111 115 8 97 101
c=IN IP4 10.198.92.126
a=rtcp:60532
a=candidate:ZHqwSbPvIZyDX24RjvIW41ryUx/QbdAiP7FyQ0yvTGo 1 Bx2Is+Wi/HJbdQKM3FIBKg UDP 0.900
10.198.92.126 60625
a=candidate:ZHqwSbPvIZyDX24RjvIW41ryUx/QbdAiP7FyQ0yvTGo 2 Bx2Is+Wi/HJbdQKM3FIBKg UDP 0.900
10.198.92.126 60532
a=crypto:2 AES_CM_128_HMAC_SHA1_80 inline:Px+rI3y4U1xd47P8USsgDc/znOiBiv5s0Ev2abRT|2^31|1:1
a=label:main-audio
a=encryption:rejected
a=rtpmap:111 SIREN/16000
a=fmtp:111 bitrate=16000
a=rtpmap:115 x-msrta/8000
a=fmtp:115 bitrate=11800
a=rtpmap:8 PCMA/8000
a=rtpmap:97 RED/8000
a=rtpmap:101 telephone-event/8000
a=fmtp:101 0-16
a=ptime:20

```

4.4.2.3 Step 12: 200 Message Is Received by the UAC

The following 200 OK message repeats the SDP answer that was sent in the preceding 183 Session Progress message.

```

SIP/2.0 200 OK
Authentication-Info: NTLM rspauth="010000003240756E24DFD336F27DB686", srand="C1DF9895",
snum="105", opaque="B25450B8", qop="auth", targetname="server1.example.com", realm="SIP
Communications Service"
Via: SIP/2.0/TLS 10.56.66.167:3137;ms-received-port=3137;ms-received-cid=100
FROM: "test1"<sip:test1@example.com>;tag=2b95504d65;epid=782abb8f70
TO: <sip:+15555550100@example.com;user=phone>;epid=6477F45221;tag=b5bb1243e3
CSEQ: 1 INVITE
CALL-ID: ca22890914c34bf8a7439dfele834420
RECORD-ROUTE: <sip:server1.example.com:5061;transport=tls;ms-role-rs-from;lr;ms-route-
sig=aaelhWZJsyQvUcPVgXY5rCBgN5MnVHAhdiIeytlQAA>
CONTACT: <sip:SH13-
LCT.example.com@example.com;gruu;opaque=srvr:MediationServer:TIRig7bu5kGXhNJb1zwQfgAA;grid=b6
796217d6ea465cbe261a778c10d5c0>;isGateway
CONTENT-LENGTH: 740
SUPPORTED: gruu-10
SUPPORTED: replaces
CONTENT-TYPE: application/sdp; charset=utf-8
ALLOW: UPDATE
P-ASSERTED-IDENTITY: <sip:+17036508897@example.com;user=phone>
SERVER: RTCC/3.0.0.0 MediationServer
ALLOW: Ack, Cancel, Bye, Invite, Refer
v=0
o=- 0 0 IN IP4 10.198.92.126
s=session
c=IN IP4 10.198.92.126
b=CT:1000
t=0 0

```

```
m=audio 60625 RTP/SAVP 111 115 8 97 101
c=IN IP4 10.198.92.126
a=rtcp:60532
a=candidate:ZHqwSbPvIZyDX24RjvIW4lryUx/QbdAiP7FyQ0yvTGo 1 Bx2Is+Wi/HJbdQKM3FIBKg UDP 0.900
10.198.92.126 60625
a=candidate:ZHqwSbPvIZyDX24RjvIW4lryUx/QbdAiP7FyQ0yvTGo 2 Bx2Is+Wi/HJbdQKM3FIBKg UDP 0.900
10.198.92.126 60532
a=crypto:2 AES_CM_128_HMAC_SHA1_80 inline:Pb+rI3y4U1xd47P8USsgDc/znOiBIv5s0Ev2abRT|2^31|1;1
a=label:main-audio
a=encryption:rejected
a=rtpmap:111 SIREN/16000
a=fmtp:111 bitrate=16000
a=rtpmap:115 x-msrta/8000
a=fmtp:115 bitrate=11800
a=rtpmap:8 PCMA/8000
a=rtpmap:97 RED/8000
a=rtpmap:101 telephone-event/8000
a=fmtp:101 0-16
a=ptime:20
```

4.5 ms-bypass SIP Supported Header Option Tag

4.5.1 Inbound Call

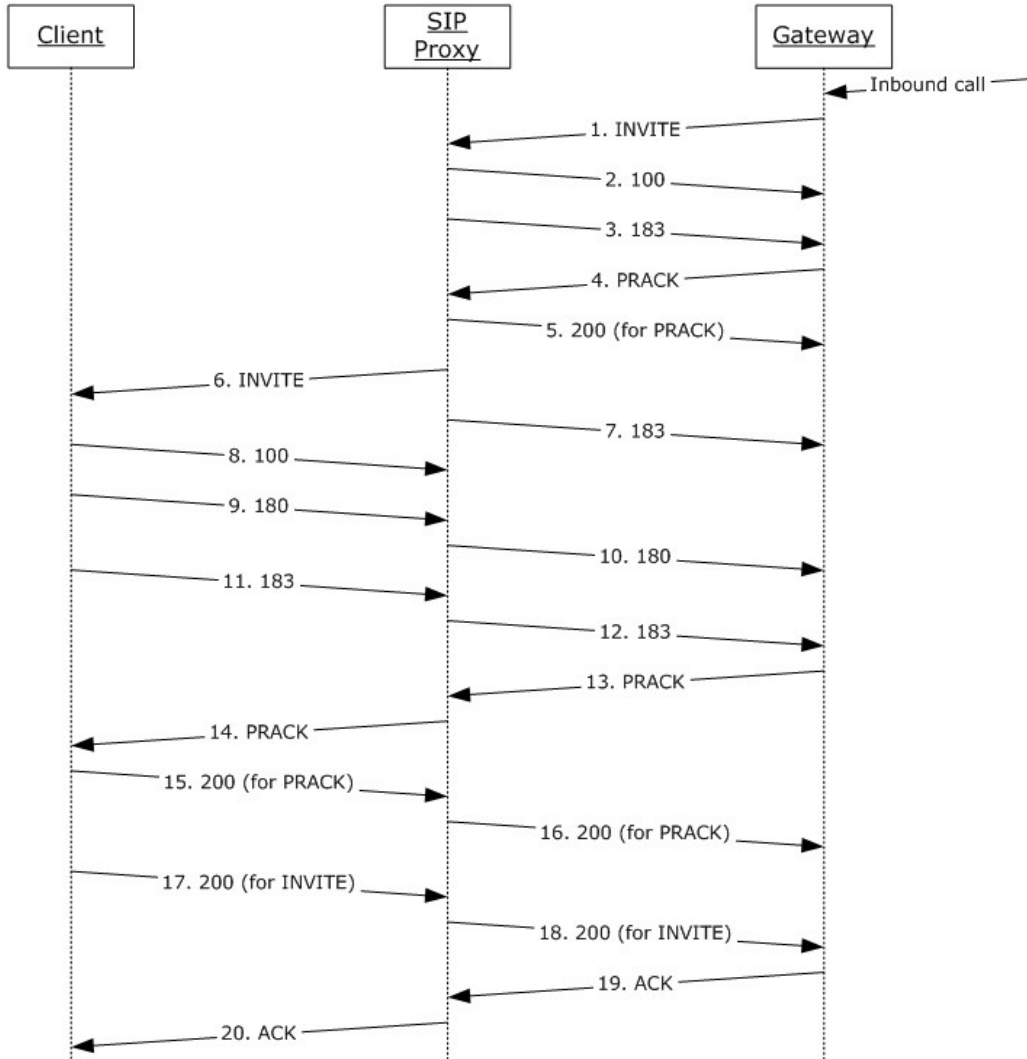

Figure 8: Inbound call

The messages in the following subsections illustrate the use of the **ms-bypass** option tag in a **Supported** header in messages that are sent from and received by a protocol client.

4.5.1.1 Step 6: INVITE Message Is Received by the Protocol Client

```
INVITE sip:192.168.1.114:4535;transport=tls;ms-opaque=acee5f6d3a;ms-received-cid=475300
SIP/2.0
Record-Route:
<sip:PROXY.company1:5061;transport=tls;opaque=state:F:Ci.R475300:Ieh.gU65xODvwq_j78KvdcC-
dRxH7lEBsv8oECfECdswTe7QW4niMEtoTOi_iwBgjHnKsZgY3jngAA;lr;ms-route-
sig=dcrEzxxvkq3iKgc2ApWyiXbCYC7NNwE-
pYCMYxgjFJ3kxFHnKsZgY3jngAA>;tag=45F7A969AE33112CB9877940D7F56D40
```

Via: SIP/2.0/TLS 10.1.1.54:5061;branch=z9hG4bK1C7C8A0E.19AB9CC7A4B7C3D3;branched=TRUE;ms-internal-info="cehce-xXzqcRs3A_ZSAwy8D4JLgyqxDKREgfIVFt6noRjHnKsZUY47CgAA"
Authentication-Info: TLS-DSK qop="auth", opaque="F755045D", srand="CC46B5FD", snum="26", rspauth="d6179291f72761e057a67adb7288fd256c2b1e4d", targetname="PROXY.company1", realm="SIP Communications Service", version=4
Max-Forwards: 69
Content-Length: 3161
Via: SIP/2.0/TLS 10.1.1.102:57350;branch=z9hG4bKe82f3c;ms-received-port=57350;ms-received-cid=475900
From: <sip:4259876543;phone-context=Location1@company1;user=phone>;epid=CDCEFEF8F18;tag=3d965223ea
To: <sip:+14251234567@company1;user=phone>;epid=54dd5867e8
CSeq: 35 INVITE
Call-ID: df601b2d-e42e-4677-b921-c9dbf4e25940
Contact:
<sip:ms5.company1@company1;gruu;opaque=srvr:MediationServer:XzRY6u68aVipMcYVfYs0hQAA;grid=bd9c42fc618147d0af4d8f84f718910b>;isGateway
Supported: replaces
Supported: ms-safe-transfer
Supported: ms-bypass
Supported: ms-dialog-route-set-update
Supported: timer
Supported: 100rel
Supported: gruu-10
User-Agent: Mediation Server
Content-Type: multipart/alternative; boundary=9dvaKhfhPJxCOyObvB70o0f2xfgiXN3J
Allow: ACK
ms-trunking-peer: gateway.company1.com;trunk=trunk1;User-Agent="Gateway 1.0"
Session-Expires: 1800
Min-SE: 90
Allow: CANCEL, BYE, INVITE, REFER, NOTIFY, PRACK, UPDATE
P-Asserted-Identity: <sip:+4259876543@company1;user=phone>
History-Info: <sip:user112@company1>;index=1
--9dvaKhfhPJxCOyObvB70o0f2xfgiXN3J
Content-Type: application/sdp
Content-ID: <72e03bb9-6acc-453b-ae09-4b8671344d83>
Content-Disposition: Session;handling=optional;ms-proxy-2007fallback
v=0
o=- 1 0 IN IP4 10.1.1.102
s=session
c=IN IP4 10.1.1.102
b=CT:1000000
t=0 0
m=audio 56568 RTP/AVP 0 8 115 13 118 97 101
c=IN IP4 10.1.1.102
a=rtcp:56569
a=candidate:wPBogiU8Nlp21GV4/zj/6WviEjTkj55FxhrdRkHiZcc 1 0tKavBj1axiy4rc19atywg UDP 0.830
10.1.1.102 56568
a=candidate:wPBogiU8Nlp21GV4/zj/6WviEjTkj55FxhrdRkHiZcc 2 0tKavBj1axiy4rc19atywg UDP 0.830
10.1.1.102 56569
a=candidate:bgLnsm3DP4aSPQloj2Ak1IUYeGDPsldLRetvScj5izM 1 5VdtqvYZImPIp0Tx5Mcg TCP 0.150
10.3.0.7 59954
a=candidate:bgLnsm3DP4aSPQloj2Ak1IUYeGDPsldLRetvScj5izM 2 5VdtqvYZImPIp0Tx5Mcg TCP 0.150
10.3.0.7 59954
a=candidate:hdj57XrOXJwib/pE8R3lzSwmfWi3trrUtRt4pmcfb5Y 1 RDbzrPzUksHqIX1Aqv0bFA UDP 0.450
10.3.0.7 55690
a=candidate:hdj57XrOXJwib/pE8R3lzSwmfWi3trrUtRt4pmcfb5Y 2 RDbzrPzUksHqIX1Aqv0bFA UDP 0.450
10.3.0.7 57652
a=candidate:JqHr0VQ3SBcleDZ+TPZ4wktouOoWH1fag30kyuLWlFQ 1 8yhh8eM+T1Z9w0CbEkzWfA TCP 0.250
10.1.1.102 207 52082

```

a=candidate:JqHr0VQ3SBcleDZ+TPZ4wktouOoWH1fag30kyuLWlFQ 2 8yhh8eM+T1Z9w0CbEkzWfA TCP 0.250
10.1.1.102 52082
a=label:main-audio
a=cryptoscale:1 client AES_CM_128_HMAC_SHA1_80
inline:f6Vl0CUyKIzjLEBRg46FFt7BenyVz1LNEk3EJ6T3|2^31|1:1
a=crypto:2 AES_CM_128_HMAC_SHA1_80 inline:P46SfAzfBRN3d06tBm787I3Pv/3j+5hOmtM1tvdv|2^31|1:1
a=crypto:3 AES_CM_128_HMAC_SHA1_80 inline:tbZ34R5hvhfBSsVLMd0/uiQ7AWOCJD5Hj+Q58HqM|2^31
a=rtpmap:0 PCMU/8000
a=rtpmap:8 PCMA/8000
a=rtpmap:115 x-msrta/8000
a=fmtp:115 bitrate=11800
a=rtpmap:13 CN/8000
a=rtpmap:118 CN/16000a=rtpmap:97 RED/8000a=rtpmap:101 telephone-event/8000a=fmtp:101 0-16,36-
9dvaKhfhPJxCOyObvB70o0f2xfgiXN3JContent-Type: application/sdpContent-ID: <d05db498-7556-
445d-86e3-bfeb36fd52e9>v=0o=- 2 0 IN IP4 10.1.1.102s=sessionc=IN IP4
10.1.1.102b=CT:1000000t=0 0m=audio 50352 RTP/AVP 0 8 115 13 118 97 101c=IN IP4
10.1.1.102a=rtcp:50353a=ice-ufrag:LxLaa=ice-pwd:3470M/yHdvxSWmMqhs+jJF2Ea=candidate:1 1 UDP
2130706431 10.1.1.102 50352 typ hosta=candidate:1 2 UDP 2130705918 10.1.1.102 50353 typ host
a=candidate:2 1 tcp-pass 6555135 10.0.3.7 55634 typ relay raddr 10.1.1.102 rport 53970
a=candidate:2 2 tcp-pass 6555134 10.0.3.7 55634 typ relay raddr 10.1.1.102 rport 53970
a=candidate:3 1 UDP 16647679 10.0.3.7 52516 typ relay raddr 10.1.1.102 rport 55636
a=candidate:3 2 UDP 16647678 10.0.3.7 58728 typ relay raddr 10.1.1.102 rport 55637
a=candidate:4 1 tcp-act 7076863 10.0.3.7 55634 typ relay raddr 10.1.1.102 rport 53970
a=candidate:4 2 tcp-act 7076350 10.0.3.7 55634 typ relay raddr 10.1.1.102 rport 53970
a=candidate:5 1 tcp-act 1684798975 10.1.1.102 53970 typ srflx raddr 10.1.1.102 rport
53970a=candidate:5 2 tcp-act 1684798462 10.1.1.102 53970 typ srflx raddr 10.1.1.102 rport
53970a=label:main-audioa=cryptoscale:1 client AES_CM_128_HMAC_SHA1_80
inline:f6Vl0CUyKIzjLEBRg46FFt7BenyVz1LNEk3EJ6T3|2^31|1:1a=crypto:2 AES_CM_128_HMAC_SHA1_80
inline:P46SfAzfBRN3d06tBm787I3Pv/3j+5hOmtM1tvdv|2^31|1:1a=crypto:3 AES_CM_128_HMAC_SHA1_80
inline:tbZ34R5hvhfBSsVLMd0/uiQ7AWOCJD5Hj+Q58HqM|2^31a=rtpmap:0 PCMU/8000a=rtpmap:8
PCMA/8000a=rtpmap:115 x-msrta/8000a=fmtp:115 bitrate=11800a=rtpmap:13 CN/8000a=rtpmap:118
CN/16000a=rtpmap:97 RED/8000a=rtpmap:101 telephone-event/8000a=fmtp:101 0-16,36-
9dvaKhfhPJxCOyObvB70o0f2xfgiXN3JContent-Type: application/gw-sdp; x-bypassid=9CD08A01-E998-
456a-AC8A-D028930E5933Content-ID: <466ac626-be34-4f8d-ba0d-c7bacf53c0ac>Content-Disposition:
Session;handling=optionalv=0o=Gateway 94331345 94331031 IN IP4 10.1.2.12s=sessionc=IN IP4
10.1.2.12t=0 0m=audio 6430 RTP/SAVP 0 8 4 2 3 13 101c=IN IP4 10.1.2.12a=rtcp:6431a=x-
bypassid:9CD08A01-E998-456a-AC8A-D028930E5933a=crypto:1 AES_CM_128_HMAC_SHA1_80
inline:uch9eRm5IMoOhc+jNRprVaEuvK2JN0upP2+9ciM9|2^31|129:1a=sendrecv=rtpmap:0
PCMU/8000a=rtpmap:8 PCMA/8000a=rtpmap:4 G723/8000a=fmtp:4 annexa=yesar=rtpmap:2 G726-
32/8000a=rtpmap:3 GSM/8000a=rtpmap:101 telephone-event/8000a=fmtp:101 0-15a=ptime:20a=x-
mediasettings:signalboostunsupported
--9dvaKhfhPJxCOyObvB70o0f2xfgiXN3J--

```

4.5.1.2 Step 17: 200 Message Is Sent by the Protocol Client

```

SIP/2.0 200 OKVia: SIP/2.0/TLS
10.1.1.54:5061;branch=z9hG4bK1C7C8A0E.19AB9CC7A4B7C3D3;branched=TRUE;ms-internal-info="cehce-
xXzqcRs3A_ZSAwy8D4JLgyqxDKREgfIVfT6noRjHnKsZUY47CGAA"Via: SIP/2.0/TLS
10.1.1.102:57350;branch=z9hG4bKe82f3c;ms-received-port=57350;ms-received-cid=475900From:
<sip:4259876543;phone-
context=Location1@company1;user=phone>;epid=CDCFEF8F18;tag=3d965223eaTo:
<sip:+14251234567@company1;user=phone>;epid=54dd5867e8;tag=c608fec21aCall-ID: df601b2d-e42e-
4677-b921-c9dbf4e25940CSeq: 35 INVITERecord-Route:
<sip:PROXY.company1:5061;transport=tls;opaque=state:F:CI.R475300:Ieh.gU65xODvwq_j78KvdcC-
dRxH7LEBsv8oECfECdswTe7QW4niMEtoToi_iwBgjHnKsZgY3jngAA;lr;ms-route-
sig=dcrEzvxvkq3iKgc2ApWyiXbCYC7NNwE-
pYCMYxjFJ3kxfHnKsZgY3jngAA>;tag=45F7A969AE33112CB9877940D7F56D40Contact:
<sip:user112@company1;opaque=user:epid:jVxLXK19112yFm93r_ArNgAA;gruu>User-Agent: Client
1.0Supported: histinfoSupported: ms-safe-transferAllow: INVITE, BYE, ACK, CANCEL, INFO,
UPDATE, REFER, NOTIFY, BENOTIFY, OPTIONSSession-Expires: 720;refresher=uacms-accepted-

```

```

content-id: <466ac626-be34-4f8d-ba0d-c7bacf53c0ac>P-Preferred-Identity:
<sip:user112@company1>, <tel:+14251234567>Supported: ms-bypassSupported: replacesProxy-
Authorization: TLS-DSK qop="auth", realm="SIP Communications Service", opaque="F755045D",
targetname="PROXY.company1", crand="bdaff021", cnum="26",
response="ec06b619fdde8d00dae6a5e3ef008db607f08538"Content-Type: application/sdpContent-
Length: 362v=0o=- 0 0 IN IP4 192.168.1.114s=sessionc=IN IP4 192.168.1.114b=CT:99980t=0
0m=audio 10228 RTP/SAVP 0 8 4 101a=crypto:1 AES_CM_128_HMAC_SHA1_80
inline:coOkWf6dIPsrYkRXi7QkjHb4n1ZwOQyZn0wWwBZR|2^31|1:1a=maxptime:200a=rtpmap:0
PCMU/8000a=rtpmap:8 PCMA/8000a=rtpmap:4 G723/8000a=rtpmap:101 telephone-event/8000a=fmtp:101
0-16a=x-bypass

```

4.5.2 Outbound Call

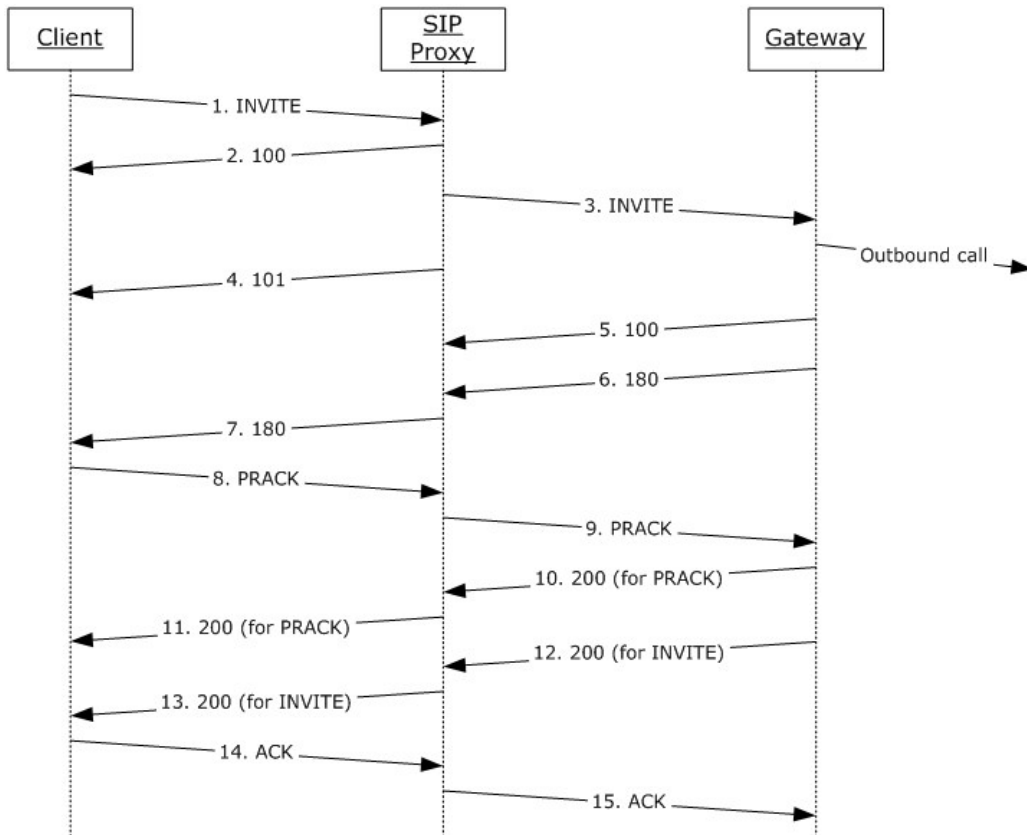

Figure 9: Outbound call

The messages in the following subsections illustrate the use of the **ms-bypass** option tag in a **Supported** header in messages that are sent from and received by a protocol client.

4.5.2.1 Step 1: INVITE Message Is Sent by the Protocol Client

```

INVITE sip:+14258901234@company1;user=phone SIP/2.0
Via: SIP/2.0/TLS 192.168.1.114:4535
Max-Forwards: 70
From: <sip:user112@company1>;tag=ed04066c4a;epid=54dd5867e8
To: <sip:+14258901234@company1;user=phone>

```

Call-ID: e571df11a45947f1a5b90da8d957b8ae
CSeq: 1 INVITE
Contact: <sip:user112@company1;opaque=user:epid:jVxLXK19112yFm93r_ArNgAA;gruu>
User-Agent: Client 1.0
Ms-Conversation-ID: AcrCQkQ2CGV+fQQpS5OprWuDL+KaYQ==
Supported: timer
Supported: histinfo
Supported: ms-safe-transfer
Supported: ms-sender
Supported: ms-early-media
Supported: 100rel
ms-keep-alive: UAC;hop-hop=yes
Allow: INVITE, BYE, ACK, CANCEL, INFO, UPDATE, REFER, NOTIFY, BENOTIFY, OPTIONS
P-Preferred-Identity: <sip:user112@company1>, <tel:+14251234567>
Supported: ms-bypass
Supported: replaces
Supported: ms-conf-invite
Proxy-Authorization: TLS-DSK qop="auth", realm="SIP Communications Service",
opaque="F755045D", targetname="PROXY.company1", crand="738839d3", cnum="12",
response="2b5e54b5d29a1493e07894772e5ce0dcca06bdf3"
Content-Type: multipart/alternative;boundary="-----_NextPart_000_0003_01CAC1FF.366488E0"
Content-Length: 3052

-----_NextPart_000_0003_01CAC1FF.366488E0

Content-Type: application/sdp
Content-Transfer-Encoding: 7bit
Content-ID: <2dd1547f1a2043c2a622586b444229e2>
Content-Disposition: session; handling=optional; ms-proxy-2007fallback

v=0
o=- 0 0 IN IP4 192.168.1.114
s=session
c=IN IP4 192.168.1.114
b=CT:99980
t=0 0
m=audio 25486 RTP/AVP 114 9 112 111 0 8 116 115 4 97 13 118 101
a=candidate:XhpPtyjMgVxDIhWFgBIMhdLFIVXLwt+YRbaobG+X43A 1 4Q/jKJde54nbJ5sfchXniA UDP 0.830
192.168.1.114 25486
a=candidate:XhpPtyjMgVxDIhWFgBIMhdLFIVXLwt+YRbaobG+X43A 2 4Q/jKJde54nbJ5sfchXniA UDP 0.830
192.168.1.114 25487
a=candidate:+oWYSe96Hnd9j7GRgjAf47ImvcM2GeoLhFH8L6sN1M 1 wiGTb6hg53yn1/Keu8TGSg TCP 0.190
10.3.0.7 57587
a=candidate:+oWYSe96Hnd9j7GRgjAf47ImvcM2GeoLhFH8L6sN1M 2 wiGTb6hg53yn1/Keu8TGSg TCP 0.190
10.3.0.7 57587
a=candidate:+LqcUBIcwtUej3u0lhJq7UET5SYTrNNWvpIzn7S4lho 1 X3SHHBGYzFqLK8TzSd5vNQ UDP 0.490
10.3.0.7 51247
a=candidate:+LqcUBIcwtUej3u0lhJq7UET5SYTrNNWvpIzn7S4lho 2 X3SHHBGYzFqLK8TzSd5vNQ UDP 0.490
10.3.0.7 50976
a=candidate:DzxkqWh6pd3wMmObq9itqTbhQ6yI4DLm1I8ZRbI3J6c 1 AUw+lgvF2GlnnLiF4otDhg TCP 0.250
192.168.1.114 50007
a=candidate:DzxkqWh6pd3wMmObq9itqTbhQ6yI4DLm1I8ZRbI3J6c 2 AUw+lgvF2GlnnLiF4otDhg TCP 0.250
192.168.1.114 50007
a=cryptoscale:1 client AES_CM_128_HMAC_SHA1_80
inline:OYlqCCFx84fwIkrR39XpPDA2HuNdtAB+6ekKly5a|2^31|1:1
a=crypto:2 AES_CM_128_HMAC_SHA1_80 inline:b28SzCBSdH7eBr13AhecN34gKh8OeCYQG6IMwxbC|2^31|1:1
a=crypto:3 AES_CM_128_HMAC_SHA1_80 inline:8LUckwDobd31ORi6KGZLYf+My7wvCwftc5Nw7G79|2^31

a=maxptime:200
a=rtpmap:114 x-msrta/16000

```

a=fmtp:114 bitrate=29000
a=rtpmap:9 G722/8000
a=rtpmap:112 G7221/16000
a=fmtp:112 bitrate=24000
a=rtpmap:111 SIREN/16000
a=fmtp:111 bitrate=16000
a=rtpmap:0 PCMU/8000
a=rtpmap:8 PCMA/8000
a=rtpmap:116 AAL2-G726-32/8000
a=rtpmap:115 x-msrta/8000
a=fmtp:115 bitrate=11800
a=rtpmap:4 G723/8000
a=rtpmap:97 RED/8000
a=rtpmap:13 CN/8000
a=rtpmap:118 CN/16000
a=rtpmap:101 telephone-event/8000
a=fmtp:101 0-16
a=encryption:optional
a=x-bypassid:9CD08A01-E998-456a-AC8A-D028930E5933

-----_NextPart_000_0003_01CAC1FF.366488E0
Content-Type: application/sdp
Content-Transfer-Encoding: 7bit
Content-ID: <3d45476919eb4c81be0c4e19c730c655>
Content-Disposition: session; handling=optional

v=0
o=- 0 0 IN IP4 192.168.1.114
s=session
c=IN IP4 192.168.1.114
b=CT:99980
t=0 0
m=audio 28238 RTP/AVP 114 9 112 111 0 8 116 115 4 97 13 118 101
a=ice-frag:ayqK
a=ice-pwd:ckRbkR221v38PhlmqvzmVe5n
a=candidate:1 1 UDP 2130706431 192.168.1.114 28238 typ host
a=candidate:1 2 UDP 2130705918 192.168.1.114 28239 typ host
a=candidate:2 1 TCP-PASS 6556159 10.3.0.7 59752 typ relay raddr 192.168.1.114 rport 50031
a=candidate:2 2 TCP-PASS 6556158 10.3.0.7 59752 typ relay raddr 192.168.1.114 rport 50031
a=candidate:3 1 UDP 16648703 10.3.0.7 50217 typ relay raddr 192.168.1.114 rport 50006
a=candidate:3 2 UDP 16648702 10.3.0.7 58942 typ relay raddr 192.168.1.114 rport 50007
a=candidate:4 1 TCP-ACT 7076863 10.3.0.7 59752 typ relay raddr 192.168.1.114 rport 50031
a=candidate:4 2 TCP-ACT 7076350 10.3.0.7 59752 typ relay raddr 192.168.1.114 rport 50031
a=candidate:5 1 TCP-ACT 1684798975 192.168.1.114 50031 typ srflx raddr 192.168.1.114 rport 50031
a=candidate:5 2 TCP-ACT 1684798462 192.168.1.114 50031 typ srflx raddr 192.168.1.114 rport 50031
a=cryptoscale:1 client AES_CM_128_HMAC_SHA1_80
inline:OY1qCCFx84fwIkrR39XpPDA2HuNdtAB+6ekKly5a|2^31|1:1
a=crypto:2 AES_CM_128_HMAC_SHA1_80 inline:b28SzCBSdH7eBr13AhecN34gKh8OeCYQG6IMwxbC|2^31|1:1
a=crypto:3 AES_CM_128_HMAC_SHA1_80 inline:8LUckwDobd31ORi6KGZLYf+My7wvCwftc5Nw7G79|2^31
a=maxptime:200
a=rtpmap:114 x-msrta/16000
a=fmtp:114 bitrate=29000
a=rtpmap:9 G722/8000
a=rtpmap:112 G7221/16000
a=fmtp:112 bitrate=24000
a=rtpmap:111 SIREN/16000
a=fmtp:111 bitrate=16000

```

```
a=rtpmap:0 PCMU/8000
a=rtpmap:8 PCMA/8000
a=rtpmap:116 AAL2-G726-32/8000
a=rtpmap:115 x-msrta/8000
a=fmtp:115 bitrate=11800
a=rtpmap:4 G723/8000
a=rtpmap:97 RED/8000
a=rtpmap:13 CN/8000
a=rtpmap:118 CN/16000
a=rtpmap:101 telephone-event/8000
a=fmtp:101 0-16
a=encryption:optional
a=x-bypassid:9CD08A01-E998-456a-AC8A-D028930E5933
```

```
-----_NextPart_000_0003_01CAC1FF.366488E0--
```

4.5.2.2 Step 13: 200 OK Message Is Received by the Protocol Client

```
SIP/2.0 200 OK
Authentication-Info: TLS-DSK qop="auth", opaque="F755045D", srand="1D9666D9", snum="17",
rspauth="3359c8ac2e6229b2eb9738ac707dc8c3e54f65f0", targetname="PROXY.company1", realm="SIP
Communications Service", version=4
Via: SIP/2.0/TLS 192.168.1.114:4535;ms-received-port=4535;ms-received-cid=475300
FROM: "user112"<sip:user112@company1>;tag=ed04066c4a;epid=54dd5867e8
TO: <sip:+14258901234@company1;user=phone>;tag=201fec487e;epid=CDCFEF8F18
CSEQ: 1 INVITE
CALL-ID: e571df11a45947f1a5b90da8d957b8ae
RECORD-ROUTE: <sip:PROXY.company1:5061;transport=tls;opaque=state:F:ci.R475300;lr;ms-route-
sig=dcw0SbeehYaHu9dRxfcQNPNLaiGM-c5DzikYU7AfKG2hHch3QtgY3jngAA>
CONTACT:
<sip:ms5.company1@company1;gruu;opaque=srvr:MediationServer:XzRY6u68aVipMcYVfYs0hQAA;grid=462
36573d0ae4a339d83726b2bf7f7ab>;isGateway
CONTENT-LENGTH: 422
SUPPORTED: replaces
SUPPORTED: ms-safe-transfer
SUPPORTED: ms-bypass
SUPPORTED: ms-dialog-route-set-update
SUPPORTED: gruu-10
SUPPORTED: timer
SUPPORTED: 100rel
CONTENT-TYPE: application/gw-sdp
ALLOW: ACK
P-ASSERTED-IDENTITY: <sip:+14258901234@company1;user=phone>
SERVER: Mediation Server
Ms-Accepted-Content-ID: <3d45476919eb4c81be0c4e19c730c655>
ms-trunking-peer: gateway.company1.com;trunk=trunk1;User-Agent="Gateway 1.0"
Allow: CANCEL,BYE,INVITE,REFER,NOTIFY,PRACK,UPDATE
Session-Expires: 1800;refresher=uas
Min-SE: 90

v=0
o=Gateway 1303417666 1303417345 IN IP4 10.1.2.12
s=session
c=IN IP4 10.1.2.12
t=0 0
m=audio 6390 RTP/SAVP 0 13 101
c=IN IP4 10.1.2.12
a=rtcp:6391
```

```

a=x-bypass
a=crypto:2 AES_CM_128_HMAC_SHA1_80 inline:bNlzDJ0LC8QYNvMIIdohDtGkWD/rCastpGbz5ObNo|2^31|244:1
a=sendrecv
a=rtpmap:0 PCMU/8000
a=rtpmap:101 telephone-event/8000
a=fmtp:101 0-15
a=ptime:20
a=x-mediasettings:signalboostunsupported

```

4.6 ms-accepted-content-id SIP Header

4.6.1 Inbound Call

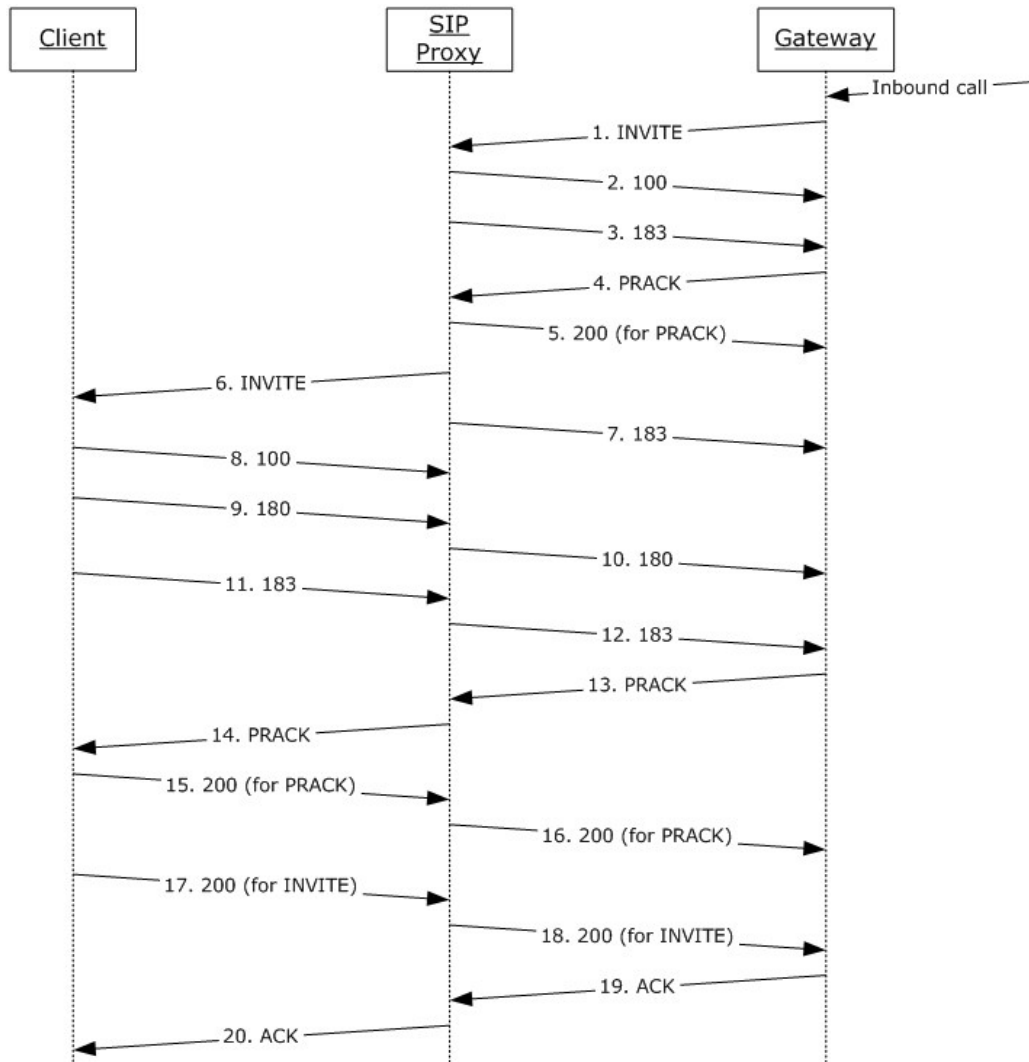

Figure 10: Inbound call

The following messages illustrate the use of the **ms-accepted-content-id** Session Initiation Protocol (SIP) header in messages that are sent from and received by a protocol client.

4.6.1.1 Step 6: INVITE Message Is Received by the Protocol Client

```
INVITE sip:192.168.1.114:4535;transport=tls;ms-opaque=acee5f6d3a;ms-received-cid=475300
SIP/2.0
Record-Route:
<sip:PROXY.company1:5061;transport=tls;opaque=state:F:Ci.R475300:Ieh.gU65xODvwq_j78KvdcC-
dRxH7LEBsv8oECfECdswTe7QW4niMEtoTOi_iwBgjHnKsZgY3jngAA;lr;ms-route-
sig=dcrEzxvkq3iKgc2ApWyIXbCYC7NNwE-
pYCMYxgjFJ3kxfHnKsZgY3jngAA>;tag=45F7A969AE33112CB9877940D7F56D40
Via: SIP/2.0/TLS 10.1.1.54:5061;branch=z9hG4bK1C7C8A0E.19AB9CC7A4B7C3D3;branched=TRUE;ms-
internal-info="cehce-xXzqcRs3A_ZSAwy8D4JLgyqxDKREgfIVFt6noRjHnKsZUY47CgAA"
Authentication-Info: TLS-DSK qop="auth", opaque="F755045D", srand="CC46B5FD", snum="26",
rspauth="d6179291f72761e057a67adb7288fd256c2b1e4d", targetname="PROXY.company1", realm="SIP
Communications Service", version=4
Max-Forwards: 69
Content-Length: 3161
Via: SIP/2.0/TLS 10.1.1.102:57350;branch=z9hG4bKe82f3c;ms-received-port=57350;ms-received-
cid=475900
From: <sip:4259876543;phone-
context=Location1@company1;user=phone>;epid=CDCFEF8F18;tag=3d965223ea
To: <sip:+14251234567@company1;user=phone>;epid=54dd5867e8
CSeq: 35 INVITE
Call-ID: df601b2d-e42e-4677-b921-c9dbf4e25940
Contact:
<sip:ms5.company1@company1;gruu;opaque=srvr:MediationServer:XzRY6u68aVipMcYVfYs0hQAA;grid=bd9
c42fc618147d0af4d8f84f718910b>;isGateway
Supported: replaces
Supported: ms-safe-transfer
Supported: ms-bypass
Supported: ms-dialog-route-set-update
Supported: timer
Supported: 100rel
Supported: gruu-10
User-Agent: Mediation Server
Content-Type: multipart/alternative; boundary=9dvaKhfhPJxCOyObvB70o0f2xfgiXN3J
Allow: ACK
ms-trunking-peer: gateway.company1.com;trunk=trunk1;User-Agent="Gateway 1.0"
Session-Expires: 1800
Min-SE: 90
Allow: CANCEL, BYE, INVITE, REFER, NOTIFY, PRACK, UPDATE
P-Asserted-Identity: <sip:+4259876543@company1;user=phone>
History-Info: <sip:user112@company1>;index=1
--9dvaKhfhPJxCOyObvB70o0f2xfgiXN3J
Content-Type: application/sdp
Content-ID: <72e03bb9-6acc-453b-ae09-4b8671344d83>
Content-Disposition: Session;handling=optional;ms-proxy-2007fallback
v=0
o=- 1 0 IN IP4 10.1.1.102
s=session
c=IN IP4 10.1.1.102
b=CT:1000000
t=0 0
m=audio 56568 RTP/AVP 0 8 115 13 118 97 101
c=IN IP4 10.1.1.102
a=rtcp:56569
a=candidate:wPBogiU8Nlp21GV4/zj/6WviEjTkj55FxhrdRkHiZcc 1 0tKavBjIaxiy4rc19atywg UDP 0.830
10.1.1.102 56568
```

```

a=candidate:wPBogiU8Nlp2lGV4/zj/6WviEjTkj55FxhrdRkHiZcc 2 0tKavBj1axiy4rc19atywg UDP 0.830
10.1.1.102 56569
a=candidate:bgLnsM3DP4aSPQloj2Ak1IUyEGDPsldLRetvScj5izM 1 5VdtqvYZImPIpTh0Tx5Mcg TCP 0.150
10.3.0.7 59954
a=candidate:bgLnsM3DP4aSPQloj2Ak1IUyEGDPsldLRetvScj5izM 2 5VdtqvYZImPIpTh0Tx5Mcg TCP 0.150
10.3.0.7 59954
a=candidate:hdj57XrOXJwib/pE8R3lzSwmfWi3trrUtRt4pmcfb5Y 1 RDbzrPzUksHqIX1Aqv0bFA UDP 0.450
10.3.0.7 55690
a=candidate:hdj57XrOXJwib/pE8R3lzSwmfWi3trrUtRt4pmcfb5Y 2 RDbzrPzUksHqIX1Aqv0bFA UDP 0.450
10.3.0.7 57652
a=candidate:JqHr0VQ3SBcleDZ+TPZ4wktouOoWH1fag30kyuLwLFQ 1 8yhh8eM+T1Z9w0CbEkzWfA TCP 0.250
10.1.1.102 207 52082
a=candidate:JqHr0VQ3SBcleDZ+TPZ4wktouOoWH1fag30kyuLwLFQ 2 8yhh8eM+T1Z9w0CbEkzWfA TCP 0.250
10.1.1.102 52082
a=label:main-audio
a=cryptoscale:1 client AES_CM_128_HMAC_SHA1_80
inline:f6Vl0CUyKIzjLEBRg46FFt7BenyVz1LLNEk3EJ6T3|2^31|1:1
a=crypto:2 AES_CM_128_HMAC_SHA1_80 inline:P46SfAzfbRN3d06tBm787I3Pv/3j+5hOmtM1tvdv|2^31|1:1
a=crypto:3 AES_CM_128_HMAC_SHA1_80 inline:tbZ34R5hvhfBSsVLMd0/uiQ7AWOCJD5Hj+Q58HQm|2^31
a=rtpmap:0 PCMU/8000
a=rtpmap:8 PCMA/8000
a=rtpmap:115 x-msrta/8000
a=fmtp:115 bitrate=11800
a=rtpmap:13 CN/8000
a=rtpmap:118 CN/16000a=rtpmap:97 RED/8000a=rtpmap:101 telephone-event/8000a=fmtp:101 0-16,36-
-9dvaKhfhPjxCoyObvB70o0f2xfgiXN3JContent-Type: application/sdpContent-ID: <d05db498-7556-
445d-86e3-bfeb36fd52e9>v=0o=- 2 0 IN IP4 10.1.1.102s=sessionc=IN IP4
10.1.1.102b=CT:1000000t=0 0m=audio 50352 RTP/AVP 0 8 115 13 118 97 101c=IN IP4
10.1.1.102a=rtcp:50353a=ice-ufrag:LxLaa=ice-pwd:3470M/yHdvxSWmMqhs+jJF2Ea=candidate:1 1 UDP
2130706431 10.1.1.102 50352 typ hosta=candidate:1 2 UDP 2130705918 10.1.1.102 50353 typ host
a=candidate:2 1 tcp-pass 6555135 10.0.3.7 55634 typ relay raddr 10.1.1.102 rport 53970
a=candidate:2 2 tcp-pass 6555134 10.0.3.7 55634 typ relay raddr 10.1.1.102 rport 53970
a=candidate:3 1 UDP 16647679 10.0.3.7 52516 typ relay raddr 10.1.1.102 rport 55636
a=candidate:3 2 UDP 16647678 10.0.3.7 58728 typ relay raddr 10.1.1.102 rport 55637
a=candidate:4 1 tcp-act 7076863 10.0.3.7 55634 typ relay raddr 10.1.1.102 rport 53970
a=candidate:4 2 tcp-act 7076350 10.0.3.7 55634 typ relay raddr 10.1.1.102 rport 53970
a=candidate:5 1 tcp-act 1684798975 10.1.1.102 53970 typ srflx raddr 10.1.1.102 rport
53970a=candidate:5 2 tcp-act 1684798462 10.1.1.102 53970 typ srflx raddr 10.1.1.102 rport
53970a=label:main-audioa=cryptoscale:1 client AES_CM_128_HMAC_SHA1_80
inline:f6Vl0CUyKIzjLEBRg46FFt7BenyVz1LLNEk3EJ6T3|2^31|1:1a=crypto:2 AES_CM_128_HMAC_SHA1_80
inline:P46SfAzfbRN3d06tBm787I3Pv/3j+5hOmtM1tvdv|2^31|1:1a=crypto:3 AES_CM_128_HMAC_SHA1_80
inline:tbZ34R5hvhfBSsVLMd0/uiQ7AWOCJD5Hj+Q58HQm|2^31a=rtpmap:0 PCMU/8000a=rtpmap:8
PCMA/8000a=rtpmap:115 x-msrta/8000a=fmtp:115 bitrate=11800a=rtpmap:13 CN/8000a=rtpmap:118
CN/16000a=rtpmap:97 RED/8000a=rtpmap:101 telephone-event/8000a=fmtp:101 0-16,36-
-9dvaKhfhPjxCoyObvB70o0f2xfgiXN3JContent-Type: application/gw-sdp; x-bypassid=9CD08A01-E998-
456a-AC8A-D028930E5933Content-ID: <466ac626-be34-4f8d-ba0d-c7bacf53c0ac>Content-Disposition:
Session;handling=optionalv=0o=Gateway 94331345 94331031 IN IP4 10.1.2.12s=sessionc=IN IP4
10.1.2.12t=0 0m=audio 6430 RTP/SAVP 0 8 4 2 3 13 101c=IN IP4 10.1.2.12a=rtcp:6431a=x-
bypassid:9CD08A01-E998-456a-AC8A-D028930E5933a=crypto:1 AES_CM_128_HMAC_SHA1_80
inline:uch9eRm5IMoOhc+jNRprVaEuvK2JN0upP2+9ciM9|2^31|129:1a=sendrecv a=rtpmap:0
PCMU/8000a=rtpmap:8 PCMA/8000a=rtpmap:4 G723/8000a=fmtp:4 annexa=yes a=rtpmap:2 G726-
32/8000a=rtpmap:3 GSM/8000a=rtpmap:101 telephone-event/8000a=fmtp:101 0-15a=ptime:20a=x-
mediasettings:signalboostunsupported
--9dvaKhfhPjxCoyObvB70o0f2xfgiXN3J-

```

4.6.1.2 Step 17: 200 Message Is Sent by the Protocol Client

```

SIP/2.0 200 OKVia: SIP/2.0/TLS
10.1.1.54:5061;branch=z9hG4bK1C7C8A0E.19AB9CC7A4B7C3D3;branched=TRUE;ms-internal-info="cehce-
xXzqcRs3A_ZSAwy8D4JLgyqxDKREgfIVFt6noRjHnKsZUY47CgAA"Via: SIP/2.0/TLS

```



```

10.1.1.102:57350;branch=z9hG4bKe82f3c;ms-received-port=57350;ms-received-cid=475900From:
<sip:4259876543;phone-
context=Location1@company1;user=phone>;epid=CDCFEF8F18;tag=3d965223eaTo:
<sip:+14251234567@company1;user=phone>;epid=54dd5867e8;tag=c608fec21aCall-ID: df601b2d-e42e-
4677-b921-c9dbf4e25940CSeq: 35 INVITERecord-Route:
<sip:PROXY.company1:5061;transport=tls;opaque=state:F:ci.R475300:Ieh.gU65xODvWq_j78KvdcC-
dRxH7LEBsv8oECfECdsWTe7QW4niMEtoTOi_iwBgjHnKsZgY3jngAA;lr;ms-route-
sig=dcrEzvxvkq3iKgc2ApWyiXbCYC7NNwE-
pYCMYxgjFJ3kxfHnKsZgY3jngAA>;tag=45F7A969AE33112CB9877940D7F56D40Contact:
<sip:user112@company1;opaque=user:epid:jVxLXK19112yFm93r_ArNgAA;gruu>User-Agent: Client
1.0Supported: histinfoSupported: ms-safe-transferAllow: INVITE, BYE, ACK, CANCEL, INFO,
UPDATE, REFER, NOTIFY, BENOTIFY, OPTIONSSession-Expires: 720;refresher=uacms-accepted-
content-id: <466ac626-be34-4f8d-ba0d-c7bacf53c0ac>P-Preferred-Identity:
<sip:user112@company1>, <tel:+14251234567>Supported: ms-bypassSupported: replacesProxy-
Authorization: TLS-DSK qop="auth", realm="SIP Communications Service", opaque="F755045D",
targetname="PROXY.company1", crand="bdaff021", cnum="26",
response="ec06b619fdde8d00dae6a5e3ef008db607f08538"Content-Type: application/sdpContent-
Length: 362v=0o=- 0 0 IN IP4 192.168.1.114s=sessionc=IN IP4 192.168.1.114b=CT:99980t=0
0m=audio 10228 RTP/SAVP 0 8 4 101a=crypto:1 AES_CM_128_HMAC_SHA1_80
inline:coOkWf6dIPsrYkRXi7QkjHb4n1ZwOQyZn0wWwBZR|2^31|1:1a=maxptime:200a=rtpmap:0
PCMU/8000a=rtpmap:8 PCMA/8000a=rtpmap:4 G723/8000a=rtpmap:101 telephone-event/8000a=fmtp:101
0-16a=x-bypass

```

4.6.2 Outbound Call

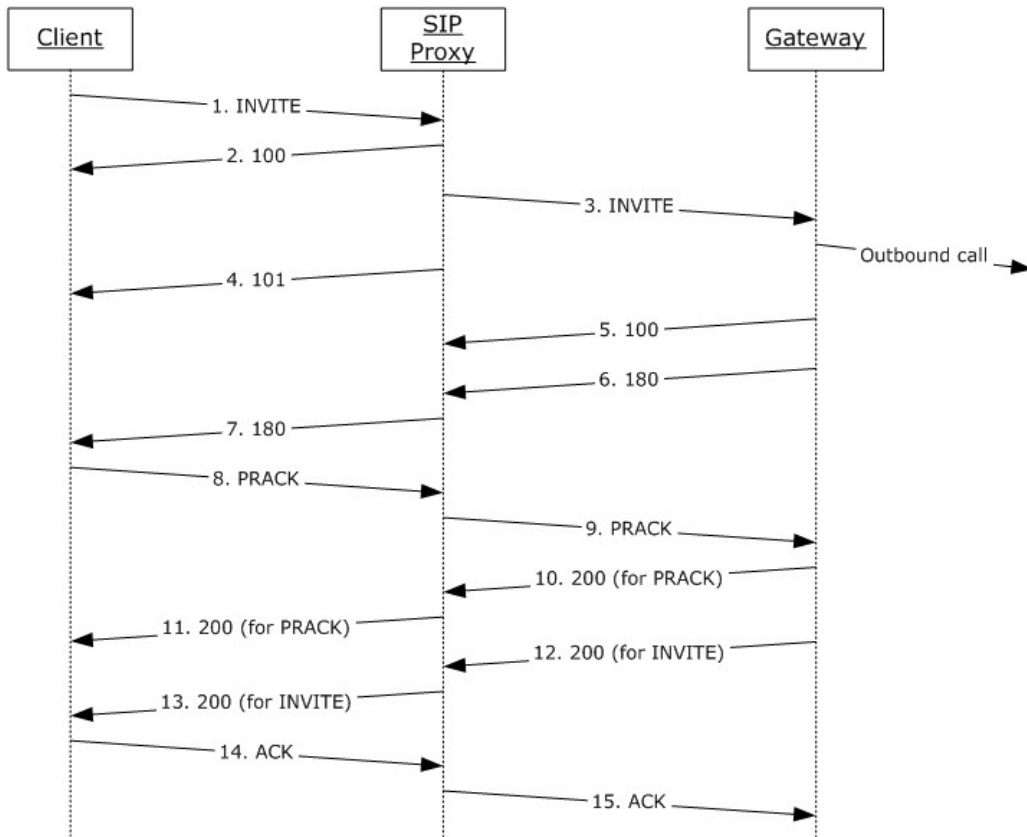

Figure 11: Outbound call

The messages in the following subsections illustrate the use of the **ms-accepted-content-id** Session Initiation Protocol (SIP) header in messages that are sent from and received by a protocol client.

4.6.2.1 Step 1: INVITE Message Is Sent by the Protocol Client

```
INVITE sip:+14258901234@company1;user=phone SIP/2.0
Via: SIP/2.0/TLS 192.168.1.114:4535
Max-Forwards: 70
From: <sip:user112@company1>;tag=ed04066c4a;epid=54dd5867e8
To: <sip:+14258901234@company1;user=phone>
Call-ID: e571df11a45947f1a5b90da8d957b8ae
CSeq: 1 INVITE
Contact: <sip:user112@company1;opaque=user:epid:jVxLXK19112yFm93r_ArNgAA;gruu>
User-Agent: Client 1.0
Ms-Conversation-ID: AcrCQkQ2CGV+fQQpS5OprWuDL+KaYQ==
Supported: timer
Supported: histinfo
Supported: ms-safe-transfer
Supported: ms-sender
Supported: ms-early-media
Supported: 100rel
ms-keep-alive: UAC;hop-hop=yes
Allow: INVITE, BYE, ACK, CANCEL, INFO, UPDATE, REFER, NOTIFY, BENOTIFY, OPTIONS
P-Preferred-Identity: <sip:user112@company1>, <tel:+14251234567>
Supported: ms-bypass
Supported: replaces
Supported: ms-conf-invite
Proxy-Authorization: TLS-DSK qop="auth", realm="SIP Communications Service",
opaque="F755045D", targetname="PROXY.company1", crand="738839d3", cnum="12",
response="2b5e54b5d29a1493e07894772e5ce0dcca06bdf3"
Content-Type: multipart/alternative;boundary="====_NextPart_000_0003_01CAC1FF.366488E0"
Content-Length: 3052

====_NextPart_000_0003_01CAC1FF.366488E0

Content-Type: application/sdp
Content-Transfer-Encoding: 7bit
Content-ID: <2dd1547f1a2043c2a622586b444229e2>
Content-Disposition: session; handling=optional; ms-proxy-2007fallback

v=0
o=- 0 0 IN IP4 192.168.1.114
s=session
c=IN IP4 192.168.1.114
b=CT:99980
t=0 0
m=audio 25486 RTP/AVP 114 9 112 111 0 8 116 115 4 97 13 118 101
a=candidate:XhpPtyjMgVxDIhWFgBIMhdLFIVXLwt+YRbaobG+X43A 1 4Q/jKJde54nbJ5sfchXniA UDP 0.830
192.168.1.114 25486
a=candidate:XhpPtyjMgVxDIhWFgBIMhdLFIVXLwt+YRbaobG+X43A 2 4Q/jKJde54nbJ5sfchXniA UDP 0.830
192.168.1.114 25487
a=candidate:+oWYSe96Hnd9j7GRgjAf47ImvcM2GeooLhFH8L6sN1M 1 wiGTb6hg53yn1/Keu8TGSg TCP 0.190
10.3.0.7 57587
a=candidate:+oWYSe96Hnd9j7GRgjAf47ImvcM2GeooLhFH8L6sN1M 2 wiGTb6hg53yn1/Keu8TGSg TCP 0.190
10.3.0.7 57587
a=candidate:+LqcUBIcwTUEj3u0lhJq7UET5SYTrNNWvpIzn7S4lho 1 X3SHHBGYzFqLK8TzSd5vnQ UDP 0.490
10.3.0.7 51247
```

```

a=candidate:+LqcUBIcwTUEj3u0lhJq7UET5SYTrNNWvpIzn7S4lho 2 X3SHHBGYzFqLK8TzSd5vNQ UDP 0.490
10.3.0.7 50976
a=candidate:DzxxkqWh6pd3wMmObq9itqTbhQ6yI4DLm1I8ZRbI3J6c 1 AUw+lgvF2GlnnLiF4otDhg TCP 0.250
192.168.1.114 50007
a=candidate:DzxxkqWh6pd3wMmObq9itqTbhQ6yI4DLm1I8ZRbI3J6c 2 AUw+lgvF2GlnnLiF4otDhg TCP 0.250
192.168.1.114 50007
a=cryptoscale:1 client AES_CM_128_HMAC_SHA1_80
inline:OY1qCCFx84fwIkrR39XpPDA2HuNdtAB+6ekKly5a|2^31|1:1
a=crypto:2 AES_CM_128_HMAC_SHA1_80 inline:b28SzCBSdH7eBr13AhecN34gKh8OeCYQG6IMwxbC|2^31|1:1
a=crypto:3 AES_CM_128_HMAC_SHA1_80 inline:8LUckwDobd31ORi6KGZLYf+My7wvCwftc5Nw7G79|2^31

a=maxptime:200
a=rtpmap:114 x-msrta/16000
a=fmtp:114 bitrate=29000
a=rtpmap:9 G722/8000
a=rtpmap:112 G7221/16000
a=fmtp:112 bitrate=24000
a=rtpmap:111 SIREN/16000
a=fmtp:111 bitrate=16000
a=rtpmap:0 PCMU/8000
a=rtpmap:8 PCMA/8000
a=rtpmap:116 AAL2-G726-32/8000
a=rtpmap:115 x-msrta/8000
a=fmtp:115 bitrate=11800
a=rtpmap:4 G723/8000
a=rtpmap:97 RED/8000
a=rtpmap:13 CN/8000
a=rtpmap:118 CN/16000
a=rtpmap:101 telephone-event/8000
a=fmtp:101 0-16
a=encryption:optional
a=x-bypassid:9CD08A01-E998-456a-AC8A-D028930E5933

-----_NextPart_000_0003_01CAC1FF.366488E0
Content-Type: application/sdp
Content-Transfer-Encoding: 7bit
Content-ID: <3d45476919eb4c81be0c4e19c730c655>
Content-Disposition: session; handling=optional

v=0
o=- 0 0 IN IP4 192.168.1.114
s=session
c=IN IP4 192.168.1.114
b=CT:99980
t=0 0
m=audio 28238 RTP/AVP 114 9 112 111 0 8 116 115 4 97 13 118 101
a=ice-frag:ayqK
a=ice-pwd:ckRbkr22lv38PhlmqvzmVe5n
a=candidate:1 1 UDP 2130706431 192.168.1.114 28238 typ host
a=candidate:1 2 UDP 2130705918 192.168.1.114 28239 typ host
a=candidate:2 1 TCP-PASS 6556159 10.3.0.7 59752 typ relay raddr 192.168.1.114 rport 50031
a=candidate:2 2 TCP-PASS 6556158 10.3.0.7 59752 typ relay raddr 192.168.1.114 rport 50031
a=candidate:3 1 UDP 16648703 10.3.0.7 50217 typ relay raddr 192.168.1.114 rport 50006
a=candidate:3 2 UDP 16648702 10.3.0.7 58942 typ relay raddr 192.168.1.114 rport 50007
a=candidate:4 1 TCP-ACT 7076863 10.3.0.7 59752 typ relay raddr 192.168.1.114 rport 50031
a=candidate:4 2 TCP-ACT 7076350 10.3.0.7 59752 typ relay raddr 192.168.1.114 rport 50031
a=candidate:5 1 TCP-ACT 1684798975 192.168.1.114 50031 typ srflx raddr 192.168.1.114 rport
50031

```

```

a=candidate:5 2 TCP-ACT 1684798462 192.168.1.114 50031 typ srflx raddr 192.168.1.114 rport
50031
a=cryptoscale:1 client AES_CM_128_HMAC_SHA1_80
inline:OYlqCCFx84fwIkrR39XpPDA2HuNdtAB+6ekKly5a|2^31|1:1
a=crypto:2 AES_CM_128_HMAC_SHA1_80 inline:b28SzCBSdH7eBr13AhecN34gKh8OeCYQG6IMwxbC|2^31|1:1
a=crypto:3 AES_CM_128_HMAC_SHA1_80 inline:8LUckwDobd3lORi6KGZLYf+My7wvCwftc5Nw7G79|2^31
a=maxptime:200
a=rtpmap:114 x-msrta/16000
a=fmtp:114 bitrate=29000
a=rtpmap:9 G722/8000
a=rtpmap:112 G7221/16000
a=fmtp:112 bitrate=24000
a=rtpmap:111 SIREN/16000
a=fmtp:111 bitrate=16000
a=rtpmap:0 PCMU/8000
a=rtpmap:8 PCMA/8000
a=rtpmap:116 AAL2-G726-32/8000
a=rtpmap:115 x-msrta/8000
a=fmtp:115 bitrate=11800
a=rtpmap:4 G723/8000
a=rtpmap:97 RED/8000
a=rtpmap:13 CN/8000
a=rtpmap:118 CN/16000
a=rtpmap:101 telephone-event/8000
a=fmtp:101 0-16
a=encryption:optional
a=x-bypassid:9CD08A01-E998-456a-AC8A-D028930E5933

-----_NextPart_000_0003_01CAC1FF.366488E0--

```

4.6.2.2 Step 13: 200 Message Is Received by the Protocol Client

```

SIP/2.0 200 OK
Authentication-Info: TLS-DSK qop="auth", opaque="F755045D", srand="1D9666D9", snum="17",
rspauth="3359c8ac2e6229b2eb9738ac707dc8c3e54f65f0", targetname="PROXY.company1", realm="SIP
Communications Service", version=4
Via: SIP/2.0/TLS 192.168.1.114:4535;ms-received-port=4535;ms-received-cid=475300
FROM: "user112"<sip:user112@company1>;tag=ed04066c4a;epid=54dd5867e8
TO: <sip:+14258901234@company1;user=phone>;tag=201fec487e;epid=CDCFEF8F18
CSEQ: 1 INVITE
CALL-ID: e571df11a45947f1a5b90da8d957b8ae
RECORD-ROUTE: <sip:PROXY.company1:5061;transport=tls;opaque=state:F:Ci.R475300;lr;ms-route-
sig=dcw0SbeehYaHu9dRxfcQPNLaiGM-c5DzikYU7AfKG2hHch3QtgY3jngAA>
CONTACT:
<sip:ms5.company1@company1;gruu;opaque=srvr:MediationServer:XzRY6u68aVipMcYVfYs0hQAA;grid=462
36573d0ae4a339d83726b2bf7f7ab>;isGateway
CONTENT-LENGTH: 422
SUPPORTED: replaces
SUPPORTED: ms-safe-transfer
SUPPORTED: ms-bypass
SUPPORTED: ms-dialog-route-set-update
SUPPORTED: gruu-10
SUPPORTED: timer
SUPPORTED: 100rel
CONTENT-TYPE: application/gw-sdp
ALLOW: ACK
P-ASSERTED-IDENTITY: <sip:+14258901234@company1;user=phone>
SERVER: Mediation Server

```

```

Ms-Accepted-Content-ID: <3d45476919eb4c81be0c4e19c730c655>
ms-trunking-peer: gateway.company1.com;trunk=trunk1;User-Agent="Gateway 1.0"
Allow: CANCEL,BYE,INVITE,REFER,NOTIFY,PRACK,UPDATE
Session-Expires: 1800;refresher=uas
Min-SE: 90

v=0
o=Gateway 1303417666 1303417345 IN IP4 10.1.2.12
s=session
c=IN IP4 10.1.2.12
t=0 0
m=audio 6390 RTP/SAVP 0 13 101
c=IN IP4 10.1.2.12
a=rtcp:6391
a=x-bypass
a=crypto:2 AES_CM_128_HMAC_SHA1_80 inline:bN1zDJ0LC8QYNvMIIdohDtGkWD/rCastpGbz5ObNo|2^31|244:1
a=sendrecv
a=rtpmap:0 PCMU/8000
a=rtpmap:101 telephone-event/8000
a=fmtp:101 0-15
a=ptime:20
a=x-mediasettings:signalboostunsupported

```

4.7 ms-trunking-peer SIP Header

The messages in the following subsections illustrate the use of the **ms-trunking-peer** Session Initiation Protocol (SIP) header in messages that are sent from and received by a protocol client.

4.7.1 Inbound Call

The message in the following subsection illustrates the use of the **ms-trunking-peer** SIP header for inbound calls. For a diagram of the inbound call, see the figure in section [4.6.1](#).

4.7.1.1 Step 6: INVITE Message Is Received by the Protocol Client

```

INVITE sip:192.168.1.114:4535;transport=tls;ms-opaque=acee5f6d3a;ms-received-cid=475300
SIP/2.0
Record-Route:
<sip:PROXY.company1:5061;transport=tls;opaque=state:F:Ci.R475300:Ieh.gU65xODvWq_j78KvdcC-
dRxH7LEBsv8oECfECdswTe7QW4niMEtoTOi_iwBgjHnKsZgY3jngAA;lr;ms-route-
sig=dcrEzxvkq3iKgc2ApWyiXbCYC7NNwE-
pYCMYxgjFJ3kxfHnKsZgY3jngAA>;tag=45F7A969AE33112CB9877940D7F56D40
Via: SIP/2.0/TLS 10.1.1.54:5061;branch=z9hG4bK1C7C8A0E.19AB9CC7A4B7C3D3;branched=TRUE;ms-
internal-info="cehce-xXzqcRs3A_ZSAwy8D4JLgyqxDKREgfIVFt6noRjHnKsZUY47CgAA"
Authentication-Info: TLS-DSK qop="auth", opaque="F755045D", srand="CC46B5FD", snum="26",
rspauth="d6179291f72761e057a67adb7288fd256c2b1e4d", targetname="PROXY.company1", realm="SIP
Communications Service", version=4
Max-Forwards: 69
Content-Length: 3161
Via: SIP/2.0/TLS 10.1.1.102:57350;branch=z9hG4bKe82f3c;ms-received-port=57350;ms-received-
cid=475900
From: <sip:4259876543;phone-
context=Location1@company1;user=phone>;epid=CDCFEF8F18;tag=3d965223ea
To: <sip:+14251234567@company1;user=phone>;epid=54dd5867e8
CSeq: 35 INVITE
Call-ID: df601b2d-e42e-4677-b921-c9dbf4e25940

```

Contact:
<ms5.companyl@company1;gruu;opaque=srvr:MediationServer:XzRY6u68aVipMcYVfYs0hQAA;grid=bd9c42fc618147d0af4d8f84f718910b>;isGateway
Supported: replaces
Supported: ms-safe-transfer
Supported: ms-bypass
Supported: ms-dialog-route-set-update
Supported: timer
Supported: 100rel
Supported: gruu-10
User-Agent: Mediation Server
Content-Type: multipart/alternative; boundary=9dvaKhfhPJxCOyObvB70o0f2xfgiXN3J
Allow: ACK
ms-trunking-peer: gateway.companyl.com;trunk=trunk1;User-Agent="Gateway 1.0"
Session-Expires: 1800
Min-SE: 90
Allow: CANCEL,BYE,INVITE,REFER,NOTIFY,PRACK,UPDATE
P-Asserted-Identity: <ms5.companyl@company1;user=phone>
History-Info: <ms5.companyl@company1>;index=1
--9dvaKhfhPJxCOyObvB70o0f2xfgiXN3J
Content-Type: application/sdp
Content-ID: <72e03bb9-6acc-453b-ae09-4b8671344d83>
Content-Disposition: Session;handling=optional;ms-proxy-2007fallback
v=0
o=- 1 0 IN IP4 10.1.1.102
s=session
c=IN IP4 10.1.1.102
b=CT:1000000
t=0 0
m=audio 56568 RTP/AVP 0 8 115 13 118 97 101
c=IN IP4 10.1.1.102
a=rtcp:56568
a=candidate:wPBogiU8NlP21GV4/zj/6WviEjTkj55FxhrdRkHiZcc 1 0tKavBjIaxiy4rc19atywg UDP 0.830
10.1.1.102 56568
a=candidate:wPBogiU8NlP21GV4/zj/6WviEjTkj55FxhrdRkHiZcc 2 0tKavBjIaxiy4rc19atywg UDP 0.830
10.1.1.102 56569
a=candidate:bgLnsM3DP4aSPQloj2Ak1IUYeGDPsldLRetvScj5izM 1 5VdtqvYZImPIpTh0Tx5Mcg TCP 0.150
10.3.0.7 59954
a=candidate:bgLnsM3DP4aSPQloj2Ak1IUYeGDPsldLRetvScj5izM 2 5VdtqvYZImPIpTh0Tx5Mcg TCP 0.150
10.3.0.7 59954
a=candidate:hdj57XrOXJwib/pE8R3lzSwmfWi3trrUtRt4pmcfb5Y 1 RDbzrPzUksHqIX1Aqv0bFA UDP 0.450
10.3.0.7 55690
a=candidate:hdj57XrOXJwib/pE8R3lzSwmfWi3trrUtRt4pmcfb5Y 2 RDbzrPzUksHqIX1Aqv0bFA UDP 0.450
10.3.0.7 57652
a=candidate:JqHr0VQ3SBcleDZ+TPZ4wktouOoWH1fag30kyuLWlFQ 1 8yhh8eM+T1Z9w0CbEkzWfA TCP 0.250
10.1.1.102 207 52082
a=candidate:JqHr0VQ3SBcleDZ+TPZ4wktouOoWH1fag30kyuLWlFQ 2 8yhh8eM+T1Z9w0CbEkzWfA TCP 0.250
10.1.1.102 52082
a=label:main-audio
a=cryptoscale:1 client AES_CM_128_HMAC_SHA1_80
inline:f6VloCUyKIzjLEBRg46FFt7BenyVz1LNEk3EJ6T3|2^31|1:1
a=crypto:2 AES_CM_128_HMAC_SHA1_80 inline:P46SfAzfbRN3d06tBm787I3Pv/3j+5hOmtM1tvDv|2^31|1:1
a=crypto:3 AES_CM_128_HMAC_SHA1_80 inline:tbZ34R5hvhfBSsVLMd0/uiQ7AWOCJD5Hj+Q58HQm|2^31
a=rtpmap:0 PCMU/8000
a=rtpmap:8 PCMA/8000
a=rtpmap:115 x-msrta/8000
a=fmtp:115 bitrate=11800
a=rtpmap:13 CN/8000
a=rtpmap:118 CN/16000a=rtpmap:97 RED/8000a=rtpmap:101 telephone-event/8000a=fmtp:101 0-16,36-
-9dvaKhfhPJxCOyObvB70o0f2xfgiXN3JContent-Type: application/sdpContent-ID: <d05db498-7556-

```

445d-86e3-bfeb36fd52e9>v=0o-- 2 0 IN IP4 10.1.1.102s=sessionc=IN IP4
10.1.1.102b=CT:1000000t=0 Om=audio 50352 RTP/AVP 0 8 115 13 118 97 101c=IN IP4
10.1.1.102a=rtcp:50353a=ice-ufrag:LxLAA=ice-pwd:3470M/yHdvxSWmMqhs+jJF2Ea=candidate:1 1 UDP
2130706431 10.1.1.102 50352 typ hosta=candidate:1 2 UDP 2130705918 10.1.1.102 50353 typ host
a=candidate:2 1 tcp-pass 6555135 10.0.3.7 55634 typ relay raddr 10.1.1.102 rport 53970
a=candidate:2 2 tcp-pass 6555134 10.0.3.7 55634 typ relay raddr 10.1.1.102 rport 53970
a=candidate:3 1 UDP 16647679 10.0.3.7 52516 typ relay raddr 10.1.1.102 rport 55636
a=candidate:3 2 UDP 16647678 10.0.3.7 58728 typ relay raddr 10.1.1.102 rport 55637
a=candidate:4 1 tcp-act 7076863 10.0.3.7 55634 typ relay raddr 10.1.1.102 rport 53970
a=candidate:4 2 tcp-act 7076350 10.0.3.7 55634 typ relay raddr 10.1.1.102 rport 53970
a=candidate:5 1 tcp-act 1684798975 10.1.1.102 53970 typ srflx raddr 10.1.1.102 rport
53970a=candidate:5 2 tcp-act 1684798462 10.1.1.102 53970 typ srflx raddr 10.1.1.102 rport
53970a=label:main-audioa=cryptoscale:1 client AES_CM_128_HMAC_SHA1_80
inline:f6VloCUyKIzjLEBRg46FFt7BenyVz1LNEk3EJ6T3|2^31|1:1a=crypto:2 AES_CM_128_HMAC_SHA1_80
inline:P46SfAzfbRN3d06tBm787I3Pv/3j+5hOmtM1tvdv|2^31|1:1a=crypto:3 AES_CM_128_HMAC_SHA1_80
inline:tbZ34R5hvhfBSsVLMd0/uiQ7AWOCJD5Hj+Q58HQm|2^31a=rtmpmap:0 PCMU/8000a=rtmpmap:8
PCMA/8000a=rtmpmap:115 x-msrta/8000a=fmtp:115 bitrate=11800a=rtmpmap:13 CN/8000a=rtmpmap:118
CN/16000a=rtmpmap:97 RED/8000a=rtmpmap:101 telephone-event/8000a=fmtp:101 0-16,36--
9dvaKhfhPJxCOyObvB70o0f2xfgiXN3JContent-Type: application/gw-sdp; x-bypassid=9CD08A01-E998-
456a-AC8A-D028930E5933Content-ID: <466ac626-be34-4f8d-ba0d-c7bacf53c0ac>Content-Disposition:
Session;handling=optionalv=0o=Gateway 94331345 94331031 IN IP4 10.1.2.12s=sessionc=IN IP4
10.1.2.12t=0 Om=audio 6430 RTP/SAVP 0 8 4 2 3 13 101c=IN IP4 10.1.2.12a=rtcp:6431a=x-
bypassid:9CD08A01-E998-456a-AC8A-D028930E5933a=crypto:1 AES_CM_128_HMAC_SHA1_80
inline:uch9eRm5IMoOhC+jNRprVaEuvK2JN0upP2+9ciM9|2^31|129:1a=sendrecva=rtmpmap:0
PCMU/8000a=rtmpmap:8 PCMA/8000a=rtmpmap:4 G723/8000a=fmtp:4 annexa=yesar=rtmpmap:2 G726-
32/8000a=rtmpmap:3 GSM/8000a=rtmpmap:101 telephone-event/8000a=fmtp:101 0-15a=ptime:20a=x-
mediasettings:signalboostunsupported
--9dvaKhfhPJxCOyObvB70o0f2xfgiXN3J--

```

4.7.2 Outbound Call

The message in the following subsection illustrates the use of the **ms-trunking-peer** SIP header for outbound calls. For a diagram of the outbound call, see the figure in section [4.6.2](#).

4.7.2.1 Step 13: 200 Message Is Received by the Protocol Client

```

SIP/2.0 200 OK
Authentication-Info: TLS-DSK qop="auth", opaque="F755045D", srand="1D9666D9", snum="17",
rspauth="3359c8ac2e6229b2eb9738ac707dc8c3e54f65f0", targetname="PROXY.company1", realm="SIP
Communications Service", version=4
Via: SIP/2.0/TLS 192.168.1.114:4535;ms-received-port=4535;ms-received-cid=475300
FROM: "user112"<sip:user112@company1>;tag=ed04066c4a;epid=54dd5867e8
TO: <sip:+14258901234@company1;user=phone>;tag=201fec487e;epid=CDCFEF8F18
CSEQ: 1 INVITE
CALL-ID: e571df11a45947f1a5b90da8d957b8ae
RECORD-ROUTE: <sip:PROXY.company1:5061;transport=tls;opaque=state:F:Ci.R475300;lr;ms-route-
sig=dcw0SbeehYaHu9dRxfCQNPNLaiGM-c5DzikYU7AfKG2hHch3QtgY3jngAA>
CONTACT:
<sip:ms5.company1@company1;gruu;opaque=svr:MediationServer:XzRY6u68aVipMcYVfYs0hQAA;grid=462
36573d0ae4a339d83726b2bf7f7ab>;isGateway
CONTENT-LENGTH: 422
SUPPORTED: replaces
SUPPORTED: ms-safe-transfer
SUPPORTED: ms-bypass
SUPPORTED: ms-dialog-route-set-update
SUPPORTED: gruu-10
SUPPORTED: timer
SUPPORTED: 100rel
CONTENT-TYPE: application/gw-sdp
ALLOW: ACK

```

```
P-ASSERTED-IDENTITY: <sip:+14258901234@company1;user=phone>
SERVER: Mediation Server
Ms-Accepted-Content-ID: <3d45476919eb4c81be0c4e19c730c655>
ms-trunking-peer: gateway.company1.com;trunk=trunk1;User-Agent="Gateway 1.0"
Allow: CANCEL,BYE,INVITE,REFER,NOTIFY,PRACK,UPDATE
Session-Expires: 1800;refresher=uas
Min-SE: 90

v=0
o=Gateway 1303417666 1303417345 IN IP4 10.1.2.12
s=session
c=IN IP4 10.1.2.12
t=0 0
m=audio 6390 RTP/SAVP 0 13 101
c=IN IP4 10.1.2.12
a=rtcp:6391
a=x-bypass
a=crypto:2 AES_CM_128_HMAC_SHA1_80 inline:bN1zDJ0LC8QYNvMIIdohDtGkWD/rCastpGbz5ObNo|2^31|244:1
a=sendrecv
a=rtpmap:0 PCMU/8000
a=rtpmap:101 telephone-event/8000
a=fmtp:101 0-15
aptime:20
a=x-mediasettings:signalboostunsupported
```

4.8 ms-mediation-generated SIP Header

The messages in the following subsections illustrate the use of the ms-mediation-generated Session Initiation Protocol (SIP) header in messages that are sent from and received by a protocol client.

4.8.1 Outbound Call

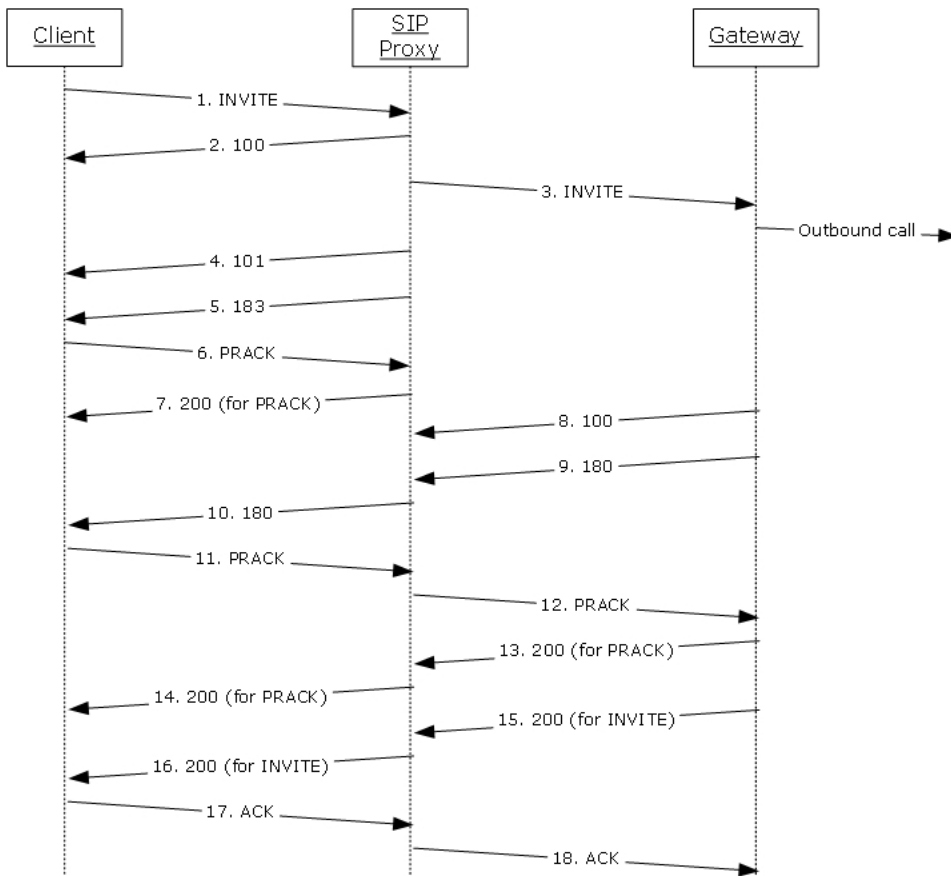

Figure 12:

Outbound call

The message in the following subsection illustrates the use of the ms-mediation-generated SIP header for outbound calls. For a diagram of the outbound call, see the preceding figure.

4.8.1.1 Step 5: 183 Message Is Received by the Protocol Client

```
SIP/2.0 183 Session Progress
Authentication-Info: NTLM rspauth="0100000000000008AC67ADF27DB686", srand="DF9D53C4",
snum="103", opaque="B25450B8", qop="auth", targetname="server1.example.com", realm="SIP
Communications Service"
Via: SIP/2.0/TLS 10.56.66.167:3137;ms-received-port=3137;ms-received-cid=100
FROM: "test1"<sip:test1@example.com>;tag=2b95504d65;epid=782abb8f70
TO: <sip:+15555550100@example.com;user=phone>;epid=6477F45221;tag=b5bb1243e3
CSEQ: 1 INVITE
CALL-ID: ca22890914c34bf8a7439dfe1e834420
ms-mediation-generated: yes
CONTENT-LENGTH: 740
CONTENT-TYPE: application/sdp; charset=utf-8
SERVER: RTCC/3.0.0.0 MediationServer
v=0
```

```
o=- 0 0 IN IP4 10.198.92.126
s=session
c=IN IP4 10.198.92.126
b=CT:1000
t=0 0
m=audio 60625 RTP/SAVP 111 115 8 97 101
c=IN IP4 10.198.92.126
a=rtcp:60532
a=candidate:ZHqwSbPvIZyDX24RjvIW41ryUx/QbdAiP7FyQ0yvTGo 1 Bx2Is+Wi/HJbdQKM3FIBKg UDP 0.900
10.198.92.126 60625
a=candidate:ZHqwSbPvIZyDX24RjvIW41ryUx/QbdAiP7FyQ0yvTGo 2 Bx2Is+Wi/HJbdQKM3FIBKg UDP 0.900
10.198.92.126 60532
a=crypto:2 AES_CM_128_HMAC_SHA1_80 inline:Pb+rI3y4U1xd47P8USsgDc/znOiBiv5s0Ev2abRT|2^31|1:1
a=label:main-audio
a=encryption:rejected
a=rtpmap:111 SIREN/16000
a=fmtp:111 bitrate=16000
a=rtpmap:115 x-msrta/8000
a=fmtp:115 bitrate=11800
a=rtpmap:8 PCMA/8000
a=rtpmap:97 RED/8000
a=rtpmap:101 telephone-event/8000
a=fmtp:101 0-16
a=ptime:20
```

4.8.1.2 Step 9: 180 Message Is Received by the Protocol Client

```
SIP/2.0 180 Ringing
Authentication-Info: NTLM rspauth="010000000000000008AC67ADF27DB686", srand="DF9D53C4",
snum="103", opaque="B25450B8", qop="auth", targetname="server1.example.com", realm="SIP
Communications Service"
Via: SIP/2.0/TLS 10.56.66.167:3137;ms-received-port=3137;ms-received-cid=100
FROM: "test1"<sip:test1@example.com>;tag=2b95504d65;epid=782abb8f70
TO: <sip:+15555550100@example.com;user=phone>;epid=6477F45221;tag=b5bb1243e3
CSEQ: 1 INVITE
CALL-ID: ca22890914c34bf8a7439dfe1e834420
CONTENT-LENGTH: 0
```

5 Security

5.1 Security Considerations for Implementers

None.

5.2 Index of Security Parameters

None.

6 Appendix A: Product Behavior

The information in this specification is applicable to the following Microsoft products or supplemental software. References to product versions include released service packs:

- Microsoft Office Communicator 2007
- Microsoft Office Communicator 2007 R2
- Microsoft Office Communications Server 2007
- Microsoft Office Communications Server 2007 R2
- Microsoft Lync 2010
- Microsoft Lync Server 2010
- Microsoft Lync 2013
- Microsoft Lync Server 2013

Exceptions, if any, are noted below. If a service pack or Quick Fix Engineering (QFE) number appears with the product version, behavior changed in that service pack or QFE. The new behavior also applies to subsequent service packs of the product unless otherwise specified. If a product edition appears with the product version, behavior is different in that product edition.

Unless otherwise specified, any statement of optional behavior in this specification that is prescribed using the terms SHOULD or SHOULD NOT implies product behavior in accordance with the SHOULD or SHOULD NOT prescription. Unless otherwise specified, the term MAY implies that the product does not follow the prescription.

[<1> Section 2.2.9:](#) This header is not available in Office Communicator 2007, Office Communicator 2007 R2, Office Communications Server 2007, Office Communications Server 2007 R2, Lync 2010, or Lync Server 2010.

[<2> Section 3.2:](#) Office Communications Server 2007, Office Communicator 2007: This behavior is not supported.

[<3> Section 3.2:](#) Office Communications Server 2007, Office Communicator 2007: This behavior is not supported.

[<4> Section 3.2:](#) Office Communications Server 2007, Office Communicator 2007: This behavior is not supported.

[<5> Section 3.2:](#) Office Communications Server 2007, Office Communicator 2007: This behavior is not supported.

[<6> Section 3.2:](#) Office Communications Server 2007, Office Communicator 2007: This behavior is not supported.

[<7> Section 3.5:](#) Office Communications Server 2007, Office Communicator 2007: This behavior is not supported.

[<8> Section 3.6:](#) Office Communications Server 2007, Office Communicator 2007, Office Communications Server 2007 R2, Office Communicator 2007 R2: This behavior is not supported.

[<9> Section 3.7:](#) Office Communications Server 2007, Office Communicator 2007, Office Communications Server 2007 R2, Office Communicator 2007 R2: This behavior is not supported.

[<10> Section 3.8:](#) Office Communications Server 2007, Office Communicator 2007, Office Communications Server 2007 R2, Office Communicator 2007 R2: This behavior is not supported.

[<11> Section 3.9:](#) This behavior is not supported in Office Communicator 2007, Office Communicator 2007 R2, Lync 2010, Office Communications Server 2007, Office Communications Server 2007 R2, or Lync Server 2010.

7 Change Tracking

No table of changes is available. The document is either new or has had no changes since its last release.

8 Index

A

Abstract data model
[anonymous phone URI](#) 20
[isGateway parameter](#) 16
[ms-accepted-content-id header](#) 22
[ms-bypass option tag](#) 21
[ms-call-source header](#) 18
[ms-early-media option tag](#) 19
[ms-mediation-generated header](#) 23
[ms-trunking-peer header](#) 22
[phone-context parameter](#) 17
[Anonymous phone URI](#) 20
[abstract data model](#) 20
[higher-layer triggered events](#) 20
[initialization](#) 20
[local events](#) 20
[message processing](#) 20
[timer events](#) 20
[timers](#) 20
[Anonymous Phone URI message](#) 14
[Applicability](#) 12

C

[Capability negotiation](#) 12
[Change tracking](#) 62
Contact header
[isGateway parameter](#) 16

E

[Examples](#) 24
[isGateway SIP contact header parameter](#) 24
[ms-accepted-content-id SIP header](#) 46
ms-bypass option tag
[inbound call](#) 39
[outbound call](#) 42
[ms-bypass SIP supported header option tag](#) 39
[ms-call-source SIP header](#) 32
[ms-early-media SIP supported header option tag](#) 34
[ms-mediation-generated SIP header](#) 56
[ms-trunking-peer SIP header](#) 53
[phone-context SIP URI parameter](#) 28
Supported header
ms-bypass option tag
[inbound call](#) 39
[outbound call](#) 42

F

[Fields - vendor-extensible](#) 12

G

[Glossary](#) 8

H

Higher-layer triggered events
[anonymous phone URI](#) 20
[isGateway parameter](#) 16
[ms-accepted-content-id header](#) 22
[ms-bypass option tag](#) 21
[ms-call-source header](#) 19
[ms-early-media option tag](#) 20
[ms-mediation-generated header](#) 23
[ms-trunking-peer header](#) 22
[phone-context parameter](#) 18

I

[Implementer - security considerations](#) 59
inbound call examples
isGateway SIP contact header parameter
[200 message sent from UAC](#) 25
[INVITE message received by UAC](#) 24
ms-accepted-content-id SIP header
[200 message sent by protocol client](#) 48
[INVITE message received by protocol client](#) 47
ms-bypass SIP supported header option tag
[200 message sent by protocol client](#) 41
[INVITE message received by protocol client](#) 39
ms-call-source SIP header
[200 message sent from UAC](#) 34
[605 message sent from UAC](#) 33
[INVITE message received by UAC - step 2](#) 32
[INVITE message received by UAC - step 8](#) 33
ms-trunking-peer SIP header
[INVITE message received by protocol client](#) 53
phone-context SIP URI parameter
[200 message sent from UAC](#) 29
[INVITE message received by UAC](#) 28
[Index of security parameters](#) 59
[Informative references](#) 9
Initialization
[anonymous phone URI](#) 20
[isGateway parameter](#) 16
[ms-accepted-content-id](#) 22
[ms-bypass option tag](#) 21
[ms-call-source header](#) 19
[ms-early-media option tag](#) 19
ms-mediation-generated header ([section 3.9](#) 23,
[section 3.9.3](#) 23)
[ms-trunking-peer](#) 22
[phone-context parameter](#) 17
[Introduction](#) 8
[isGateway](#) 16
[abstract data model](#) 16
[higher-layer triggered events](#) 16
[initialization](#) 16
[local events](#) 16
[message processing](#) 16
[timer events](#) 16
[timers](#) 16
[isGateway message](#) 13
[isGateway SIP contact header parameter example](#) 24

- [inbound call](#) 24
 - [200 message sent from UAC](#) 25
 - [INVITE message received by UAC](#) 24
- [outbound call](#) 26
 - [200 message received by UAC](#) 27
 - [INVITE message sent from UAC](#) 26

L

Local events

- [anonymous phone URI](#) 20
- [isGateway parameter](#) 16
- [ms-accepted-content-id header](#) 22
- [ms-bypass option tag](#) 21
- [ms-call-source header](#) 19
- [ms-early-media option tag](#) 20
- [ms-trunking-peer header](#) 23
- [phone-context parameter](#) 18

M

Message processing

- [anonymous phone URI](#) 20
- [isGateway parameter](#) 16
- [ms-accepted-content-id header](#) 22
- [ms-bypass option tag](#) 21
- [ms-call-source header](#) 19
- [ms-early-media option tag](#) 20
- [ms-mediation-generated header](#) 23
- [ms-trunking-peer header](#) 22
- [phone-context parameter](#) 18

Message syntax 13

Messages

- [Anonymous Phone URI](#) 14
- [isGateway](#) 13
- [ms-accepted-content-id](#) 14
- [ms-bypass](#) 14
- [ms-call-source](#) 14
- [ms-early-media](#) 14
- [ms-mediation-generated](#) 15
- [ms-trunking-peer](#) 15
- [phone-context](#) 13
- [syntax](#) 13
- [transport](#) 13

[ms-accepted-content-id](#) 21

- [abstract data model](#) 22
- [higher-layer triggered events](#) 22
- [initialization](#) 22
- [local events](#) 22
- [message processing](#) 22
- [timer events](#) 22
- [timers](#) 22

[ms-accepted-content-id message](#) 14

[ms-accepted-content-id SIP header example](#) 46

- [inbound call](#) 46
 - [200 message sent by protocol client](#) 48
 - [INVITE message received by protocol client](#) 47
- [outbound call](#) 49
 - [200 message received by protocol client](#) 52
 - [INVITE message sent by protocol client](#) 50

[ms-bypass](#) 21

- [abstract data model](#) 21

- [example](#)
 - [inbound call](#) 39
 - [outbound call](#) 42
- [higher-layer triggered events](#) 21
- [initialization](#) 21
- [local events](#) 21
- [message processing](#) 21
- [timer events](#) 21
- [timers](#) 21

[ms-bypass message](#) 14

[ms-bypass SIP supported header option tag example](#) 39

- [inbound call](#) 39
 - [200 message sent by protocol client](#) 41
 - [INVITE message received by protocol client](#) 39
- [outbound call](#) 42
 - [200 OK message received by protocol client](#) 45
 - [INVITE message sent by protocol client](#) 42

[ms-call-source](#) ([section 3.3](#) 18, [section 3.4](#) 19)

- [abstract data model](#) 18
- [higher-layer triggered events](#) 19
- [initialization](#) 19
- [local events](#) 19
- [message processing](#) 19
- [timer events](#) 19
- [timers](#) 18

[ms-call-source message](#) 14

[ms-call-source SIP header example](#) 32

- [inbound call](#) 32
 - [605 message sent from UAC](#) 33
 - [I200 message sent from UAC](#) 34
 - [INVITE message received by UAC – step 2](#) 32
 - [INVITE message received by UAC – step 8](#) 33
- [outbound call](#) 34

[ms-early-media](#)

- [abstract data model](#) 19
- [higher-layer triggered events](#) 20
- [initialization](#) 19
- [local events](#) 20
- [message processing](#) 20
- [timer events](#) 20
- [timers](#) 19

[ms-early-media message](#) 14

[ms-early-media SIP supported header option tag example](#) 34

- [inbound call](#) 34
- [outbound call](#) 35
 - [183 message received by UAC](#) 36
 - [200 message received by UAC](#) 37
 - [INVITE sent from UAC](#) 35

[ms-mediation-generated](#) 23

- [abstract data model](#) 23
- [higher-layer triggered events](#) 23
- [initialization](#) ([section 3.9](#) 23, [section 3.9.3](#) 23)
- [message processing](#) 23
- [other local events](#) 23
- [timer events](#) 23
- [timers](#) 23

[ms-mediation-generated message](#) 15

[ms-mediation-generated SIP header example](#) 56

- [outbound call](#) 57

- [180 message received by protocol client](#) 58
- [183 message received by protocol client](#) 57
- [ms-trunking-peer](#) 22
 - [abstract data model](#) 22
 - [higher-layer triggered events](#) 22
 - [initialization](#) 22
 - [local events](#) 23
 - [message processing](#) 22
 - [timer events](#) 23
 - [timers](#) 22
- [ms-trunking-peer message](#) 15
- [ms-trunking-peer SIP header example](#) 53
 - [inbound call](#) 53
 - [INVITE message received by protocol client](#) 53
 - [outbound call](#) 55
 - [200 message received by protocol client](#) 55

N

- [Normative references](#) 9

O

- Other local events
 - [ms-mediation-generated header](#) 23
- outbound call examples
 - isGateway SIP contact header parameter
 - [200 message received by UAC](#) 27
 - [INVITE message sent from UAC](#) 26
 - ms-accepted-content-id SIP header
 - [200 message received by protocol client](#) 52
 - [INVITE message sent by protocol client](#) 50
 - ms-bypass SIP supported header option tag
 - [200 OK message received by protocol client](#) 45
 - [INVITE message sent by protocol client](#) 42
 - ms-early-media SIP supported header option tag
 - [183 message received by UAC](#) 36
 - [200 message received by UAC](#) 37
 - [INVITE sent from UAC](#) 35
 - ms-mediation-generated SIP header
 - [180 message received by protocol client](#) 58
 - [183 message received by protocol client](#) 57
 - ms-trunking-peer SIP header
 - [200 message received by protocol client](#) 55
 - phone-context SIP URI parameter
 - [200 message received by UAC](#) 31
 - [INVITE message sent from UAC](#) 30

[Overview \(synopsis\)](#) 10

P

- [Parameters - security index](#) 59
- [phone-context](#) 16
 - [abstract data model](#) 17
 - [higher-layer triggered events](#) 18
 - [initialization](#) 17
 - [local events](#) 18
 - [message processing](#) 18
 - [timer events](#) 18
 - [timers](#) 17
- [phone-context message](#) 13
- [phone-context SIP URI parameter example](#) 28

- [inbound call](#) 28
 - [200 message sent from UAC](#) 29
 - [INVITE message received by UAC](#) 28
- [outbound call](#) 30
 - [200 message received by UAC](#) 31
 - [INVITE message sent from UAC](#) 30
- [Preconditions](#) 12
- [Prerequisites](#) 12
- [Product behavior](#) 60

R

- [References](#) 9
 - [informative](#) 9
 - [normative](#) 9
- [Relationship to other protocols](#) 11

S

- Security
 - [implementer considerations](#) 59
 - [parameter index](#) 59
- SIP headers
 - [ms-accepted-content-id](#) 21
 - [ms-bypass option tag](#) 21
 - [ms-call-source](#) 18
 - [ms-early-media option tag](#) 19
 - [ms-mediation-generated](#) 23
 - [ms-trunking-peer](#) 22
- SIP URI
 - [phone-context parameter](#) 16
- [Standards assignments](#) 12
- Supported header
 - ms-bypass option tag
 - example
 - [inbound call](#) 39
 - [outbound call](#) 42

T

- Timer events
 - [anonymous phone URI](#) 20
 - [isGateway parameter](#) 16
 - [ms-accepted-content-id header](#) 22
 - [ms-bypass option tag](#) 21
 - [ms-call-source header](#) 19
 - [ms-early-media option tag](#) 20
 - [ms-mediation-generated header](#) 23
 - [ms-trunking-peer header](#) 23
 - [phone-context parameter](#) 18
- Timers
 - [anonymous phone URI](#) 20
 - [isGateway parameter](#) 16
 - [ms-accepted-content-id header](#) 22
 - [ms-bypass option tag](#) 21
 - [ms-call-source header](#) 18
 - [ms-early-media option tag](#) 19
 - [ms-mediation-generated header](#) 23
 - [ms-trunking-peer header](#) 22
 - [phone-context parameter](#) 17
- [Tracking changes](#) 62
- [Transport](#) 13

V

[Vendor-extensible fields](#) 12
[Versioning](#) 12